

PROJECT NAME: _____ LOCATION: _____

ITEM: _____ MODEL: _____

Commercial Gas Range



The Centaur Commercial Gas Range has powerful Planck 30,000 BTU cast iron burners. Each burner has a lift off head - individual pilot light - heavy duty 12" x 12" removable cast iron grate and individual instant light control knob. It is constructed with a stainless steel front, 24.75" high backriser and shelf, 6" adjustable stainless steel legs or casters and a 3/4" NPT gas connection.

The standard oven is powered with a 30,000 BTU Burner and comes with two easy to remove oven racks. It includes a porcelain oven liner for easy cleaning and a compression spring door hinge system for durability. The oven thermostat adjusts from 200°F - 500°F and is equipped with a flame failure safety device.

FEATURES LIST

CR4-N, CR6-N, CR10-N

CR4-P, CR6-P, CR10-P

- 30,000 Planck cast iron burners
 - Lift off heads
 - Individual pilot lights
 - Heavy duty 12" x 12" removable cast iron grates
 - Flame adjustable control knobs
- Full Size Oven
 - 30,000 BTU oven burner
 - Cool to touch oven door handle
 - Two adjustable oven racks easily removable
 - Compression spring door system
 - Flame failure safety device
 - Adjustable thermostat: 200°F – 500°F
 - R6 & R10 hold full size sheet pans
- Construction
 - Heavy duty steel frame
 - Stainless Steel front – 24.75" high backriser and shelf
 - Removable crumb tray under the top burners
 - 6" adjustable Stainless steel legs or casters
 - 3/4" NPT gas connection



Specifications subject to change without notice

PLAN VIEW

- A pressure regulator is provided with this unit.
Natural Gas 4.0" W.C.
Propane Gas 10.0" W.C.
- Rear Gas Connection 3/4" NPT

CR4-N/ CR4-P
24"

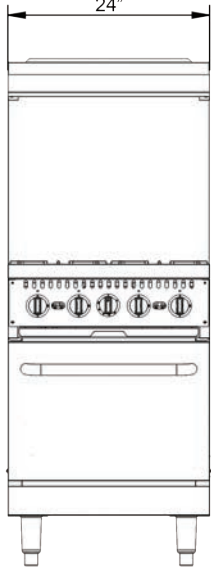

CR4-N/ CR4-P

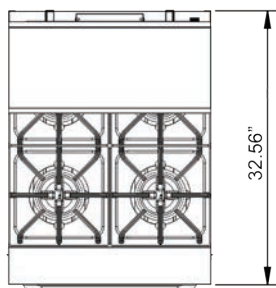

CR6-N / CR6-P

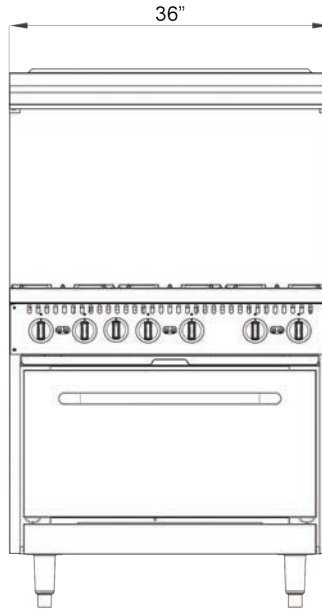

All Units

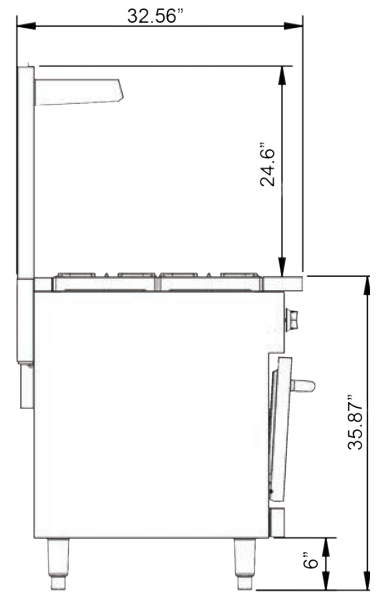

CR10-N / CR10-P

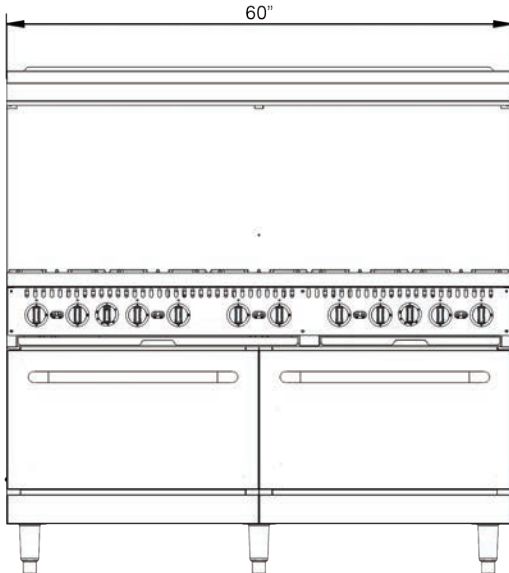

CR6-N / CR6-P

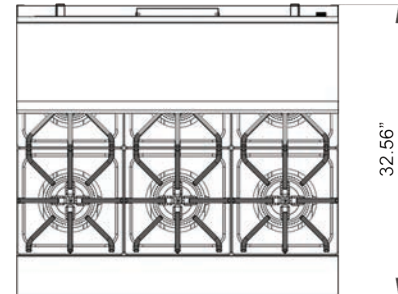

CR10-N / CR10-P

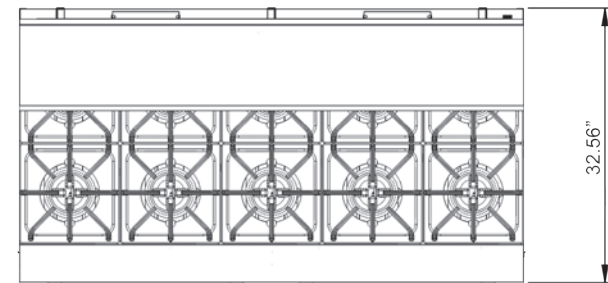

Model	Burners	External Dimensions			Internal Oven Dimensions			BTU's (per burner)	BTU's (per oven)	Total BTU's	Crated Weight (lbs)
		W	D	H	W	D	H				
CR4-N / CR4-P	4	24	32.56	35.9+24.6	20.6	25.8	13.7	30,000	30,000	150,000	356
CR6-N / CR6-P	6	36	32.56	35.9+24.6	26.8	25.8	13.7	30,000	30,000	210,000	455
CR10-N / CR10-P	10	60	32.56	35.9+24.6	26.8	25.8	13.7	30,000	30,000 x 2	360,000	737