

Click here to buy now!



FEATURES LIST

CR6-G12, CR6-G24, CR10-G24

- **Top Burner**
 - Cast iron burners each giving off 30,000 BTU/hour
 - 12" x 12" cast iron top grates are removable for easy cleaning
 - Each burner has an individual standing pilot light
 - Push in knob with efficient Hi-Low burner system
 - Removable crumb tray
- **Griddle**
 - 3/4" thick griddle plate
 - 4" welded griddle side shields
 - Stainless Steel "U" burner
 - Heat every 6" — valve control every 12"
- **Oven**
 - 30,000 BTU/hr total output
 - Flame failure safety device
 - Adjustable thermostat from 200°F – 450°F
 - Steel liner on door and sides with a porcelain oven liner
 - Includes 2 removable and adjustable oven racks
 - Cool to touch stainless steel oven door handles
- **Construction**
 - Stainless steel front, back riser and shelf
 - Spring loaded door with cool to touch stainless steel oven door handle
 - 6" stainless steel adjustable legs
 - 3/4" rear NPT gas connection

Optional Accessory:

-

Specifications subject to change without notice

Click here to buy now!

PLAN VIEW

- A pressure regulator is provided with this unit.
 Natural Gas 4.0" W.C.
 Propane Gas 10.0" W.C.
- Rear Gas Connection ¾" NPT

CR6-G12

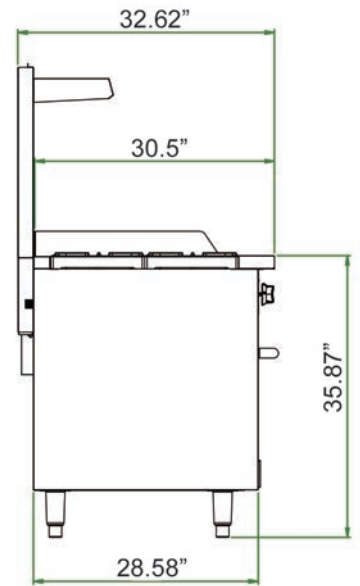
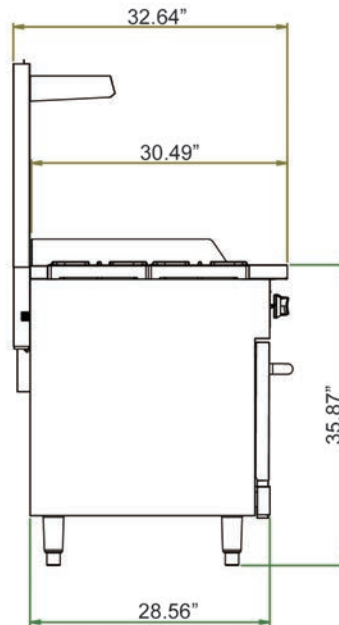
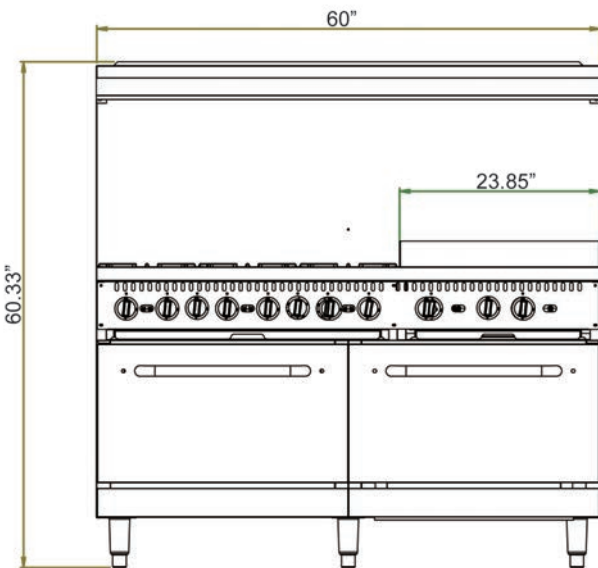
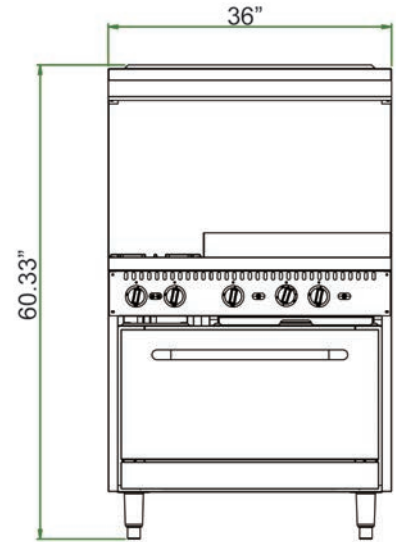
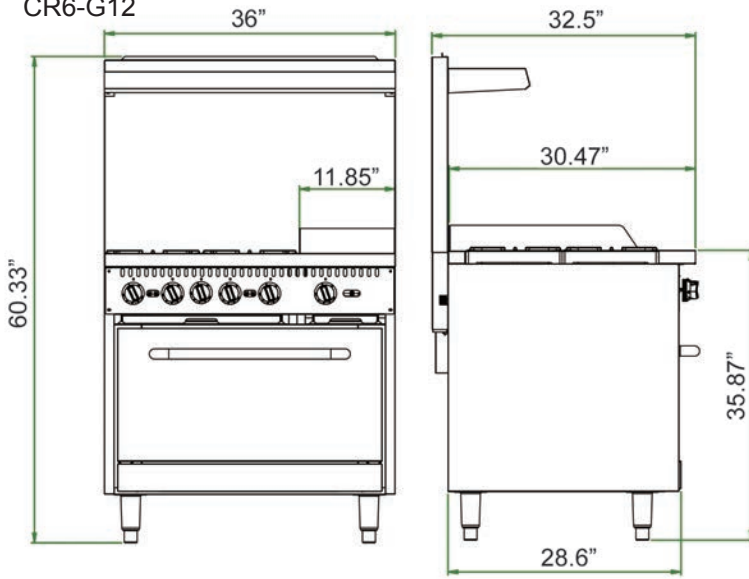

Model	Burners	External Dimensions			Internal Oven Dimensions			BTU's (per burner)	BTU's (per oven)	Total BTU's	Crated Weight (lbs)
		W	D	H	W	D	H				
CR6-G12	4	36	32.5	60.33	26.88	25.8	13.8	30,000	30,000	150,000	460
CR6-G24	2	36	32.5	35.9+24.6	26.88	25.8	13.8	30,000	30,000	210,000	507
CR10-G24	6	60	32.5	35.9+24.6	26.88	25.8	13.8	30,000	30,000 x 2	360,000	816