



# VEGETABLE PREPARATION MACHINE CA-31

Vegetable preparation machine. Production up to 450 kg/hour.



## SALES DESCRIPTION

Single-speed motor block + Regular hopper.

## FEATURES AND BENEFITS

### A perfect cut

- ✓ High precision adjustments to obtain a uniform and excellent-quality cut.
- ✓ It can be fitted with a wide range of discs and grids of the highest cutting quality. Combining these accessories together to obtain more than 70 different types of cuts and grating grades.

### Built to last

- ✓ Made from stainless steel and food-grade materials of the highest quality: stainless steel motor block and food-grade aluminium head.
- ✓ High power asynchronous motor.

### Maximum comfort for the user

- ✓ Ergonomic design: product sliced in one single movement.
- ✓ Lateral product output: requires less space on the worktop and guides the product, avoiding splashes.
- ✓ The electronic command panel is very intuitive.

### Maintenance, safety, hygiene

- ✓ Lever and lid easily removable for cleaning purposes.
- ✓ Combination of safety systems: head, cover, power switch.
- ✓ Appliance certified by NSF International (regulations on hygiene, cleaning and materials suitable for contact with foods).
- ✓ 100% tested.

## INCLUDES

- ✓ Single-speed motor block.
- ✓ Regular hopper.

## ACCESSORIES

- FCC Curved Slicing Discs
- FCO Rippled Slicing Discs
- FFC Chipping Grids
- FMC Dicing Grids
- FCE Julienne Discs
- FR Shredding & Grating Discs
- Long vegetable attachment
- Disc and Grid Holder
- Stand-trolley
- Grid Cleaning Kit
- FC-D Slicing Discs
- SH Shredding & Grating Discs  
:: NEW: Detachable without tools & dishwasher safe



**sammic** | [www.sammic.com](http://www.sammic.com)  
Food Service Equipment Manufacturer

Polígono Basarte, 1. phone +34 943 15 72 36  
20720 Azkoitia, Spain sales@sammic.com



Project	Date
Item	Qty
Approved	

DYNAMIC PREPARATION  
COMMERCIAL VEGETABLE PREPARATION MACHINES

product sheet  
updated 09/01/2020



# VEGETABLE PREPARATION MACHINE CA-31

Vegetable preparation machine. Production up to 450 kg/hour.



## SPECIFICATIONS

**Hourly production:** 150 Kg - 450 Kg

**Inlet opening:** 136 cm<sup>2</sup>

**Disc diameter:** 205 mm

**Motor speed:** 365 rpm

**Loading**

Single Phase: 550 W

Three phase: 370 W

**Noise level (1m.):** <70 dB(A)

**Background noise:** 32 dB(A)

**External dimensions (WxDxH)**

Width: 389 mm

Depth: 405 mm

Height: 544 mm

**Net weight:** 21 Kg

**Crated dimensions**

435 x 430 x 600 mm

Volume Packed: 0.11 m<sup>3</sup>

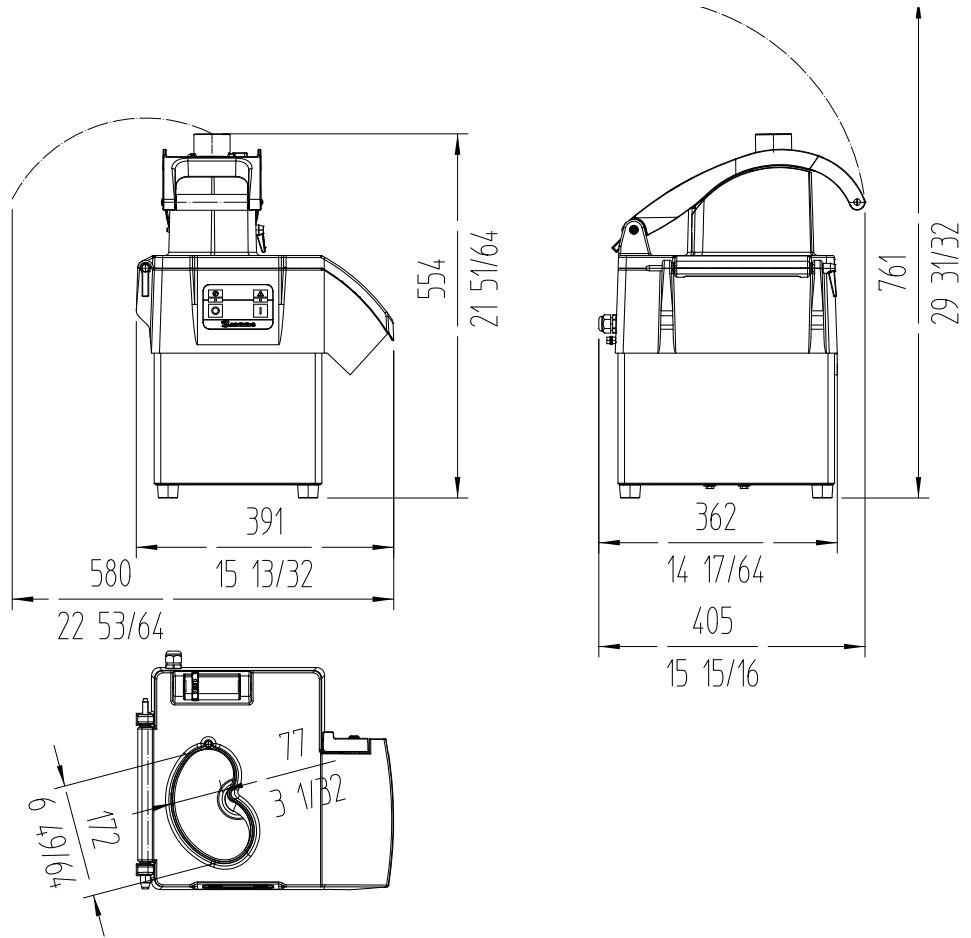

## AVAILABLE MODELS

1050701	Vegetable preparation machine CA-31 230-400/50/3N
1050700	Vegetable preparation machine CA-31 230/50/1
1050702	Vegetable preparation machine CA-31 120/60/1
1050704	Vegetable preparation machine CA-31 220/60/1 K
1050705	Vegetable preparation machine CA-31 220/60/1
1050706	Vegetable preparation machine CA-31 220/60/1 KSA
1050707	Vegetable preparation machine CA-31 220-380/60/3N
1050708	Vegetable preparation machine CA-31 230/50/1 AUS
1050712	Vegetable preparation machine CA-31 230/50/1

\* Ask for special versions availability

**sammic** | www.sammic.com  
Food Service Equipment Manufacturer

Polígono Basarte, 1. phone +34 943 15 72 36  
20720 Azkoitia, Spain sales@sammic.com



Project	Date
Item	Qty
Approved	

DYNAMIC PREPARATION  
COMMERCIAL VEGETABLE PREPARATION MACHINES

product sheet  
updated 09/01/2020