



VACUUM PACKING MACHINE SU-6100GP+ 220/60/3

Double chamber vacuum packing machine. 100m³/h.



Cód. 1141048

FEATURES AND BENEFITS

- ✓ Powered by Busch.
- ✓ Vacuum controlled by sensor.
- ✓ Vacuum PLUS.
- ✓ LCD colour screen: all information at a glance.
- ✓ Backlit touch keyboard.
- ✓ Programmable: 25-programme memory. Blocking option.
- ✓ "Pause" button.
- ✓ Phased vacuum programme.
- ✓ Detection of the evaporation of liquids.
- ✓ Double seal.
- ✓ Cordless sealing bar.
- ✓ Progressive decompression.
- ✓ Vac-Norm ready with Automatic decompression.
- ✓ Stainless steel body and chambers.
- ✓ Tilting cover made of thick, robust stainless steel.
- ✓ Dry-oil programme for drying the pump.
- ✓ Working hours counter for oil changes.
- ✓ Safety system with protection against vacuum failure.
- ✓ NSF-listed.

INCLUDES

- ✓ 4 filling plates
- ✓ Bluetooth connectivity
- ✓ Printer connection
- ✓ "Plus" sealing system



SALES DESCRIPTION

High performance model with tilting cover, double chamber and 4 x 662 mm. sealing bars.

100 m³/h Busch vacuum pump.

Vacuum controlled by sensor.



sammic | www.sammic.us
Food Service Equipment Manufacturer

usa@sammic.com phone +1 (224) 307-2232
1225 Hartrey Avenue toll free +1 844 275 3848
60202-1056 Evanston, IL



Project	Date
Item	Qty
Approved	

FOOD PRESERVATION AND SOUS-VIDE
VACUUM PACKING MACHINES - "SENSOR ULTRA" LINE

product sheet
updated 19/04/2018



VACUUM PACKING MACHINE SU-6100GP+ 220/60/3

Double chamber vacuum packing machine. 100m³/h.



Cód. 1141048

SPECIFICATIONS

Pump capacity: 3500 cf/h
 Bar length: 26 " + 26 "
 Total loading: 3 Hp
 Vacuum pressure (maximum): 0.5 mbar
 Electrical supply: 220 V--- V / 60 Hz / 3 ~
 (12.1 A)

Internal dimensions

- ✓ Width: 26 "
- ✓ Depth: 25.8 "
- ✓ Height: 8 "

External dimensions (WxDxH)

- ✓ Width: 65 "
- ✓ Depth: 35 "
- ✓ Height: 54 "

Net weight: 794 lbs.

Noise level (1m.): 75 dB(A)

Background noise: 32 dB(A)

Crated dimensions

980 x 1720 x 1280 mm

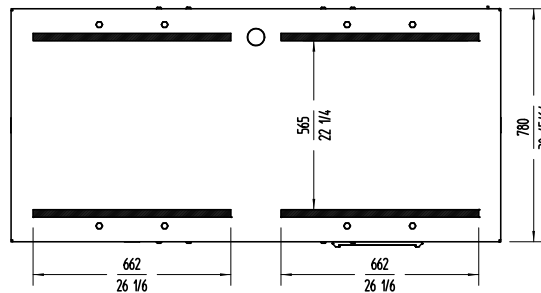
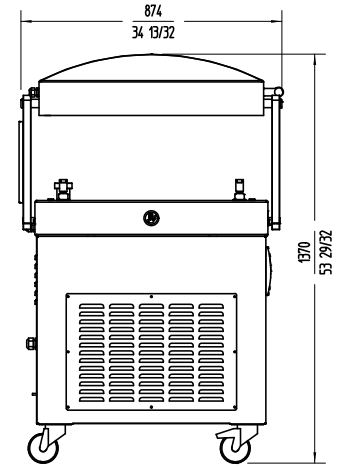
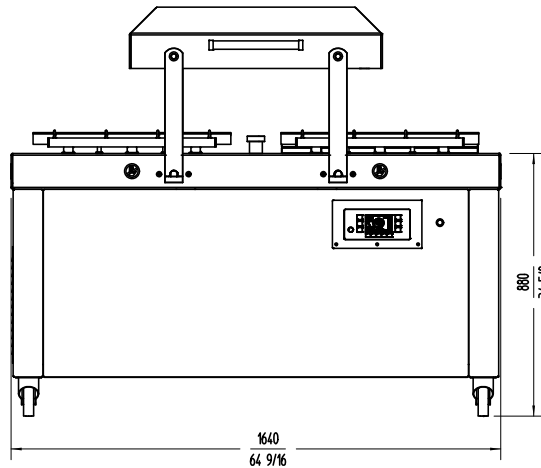

ACCESSORIES

- Bag cutting kits
- Filling plates
- Liquid insert plates
- Vac-norm external vacuum kits
- Vac-norm containers
- Smooth bags for vacuum packing
- CG2 Desktop printer for SU vacuum packing machines *
- Thermal labels for CG2 printer

FOOD PRESERVATION AND SOUS-VIDE
VACUUM PACKING MACHINES - "SENSOR ULTRA" LINE

sammic | www.sammic.us
 Food Service Equipment Manufacturer

usa@sammic.com phone +1 (224) 307-2232
 1225 Hartrey Avenue toll free +1 844 275 3848
 60202-1056 Evanston, IL



Project	Date
Item	Qty
Approved	