



CUTLERY DRYER SAS-5001

Floorstanding flatware polishing machine.

WARE WASHING
CUTLERY DRYERS



SALES DESCRIPTION

Output: up to 8000 pieces per hour

- ✓ Dries, polishes and removes lime scale stains from cutlery after washing.
- ✓ Fully automatic.
- ✓ Stainless steel body and polishing tank.
- ✓ Rounded cutlery carousel, avoiding cutlery jams.
- ✓ Economy: saves on personnel costs and quick return of investment.
- ✓ Speed: hourly output of up to 8,000 pieces.
- ✓ Hygiene: the germicidal UVC-ray lamp sterilises both the cutlery and the polishing product.

INCLUDES

- ✓ Germicidal UVC-ray lamp.
- ✓ Drying-polishing product 5kg.

ACCESSORIES

- Polishing product
- Front Wheel Kit



SAMMIC, S.L.
Bszarte, 1 - 20720 AzkOITIA
www.sammic.com

sammic | www.sammic.us
Food Service Equipment Manufacturer

usa@sammic.com phone +1 (224) 307-2232
 1225 Hartrey Avenue toll free +1 844 275 3848
 60202-1056 Evanston, IL



Project	Date
Item	Qty
Approved	

product sheet
updated 01/11/21



CUTLERY DRYER SAS-5001

Floorstanding flatware polishing machine.

WARE WASHING
CUTLERY DRYERS

SPECIFICATIONS

Hourly production (pieces): 5000 - 8000

Electrical supply: 120V / 60 Hz / 1~ (10 A)

Loading

- ✓ Motor power: 0.37 Hp
- ✓ Element power: 1.25 Hp
- ✓ Uvc lamp power: 8 W

External dimensions (WxDxH)

- ✓ Width: 25 "
- ✓ Depth: 27(31) "
- ✓ Height: 31 "

Net weight: 287 lbs.

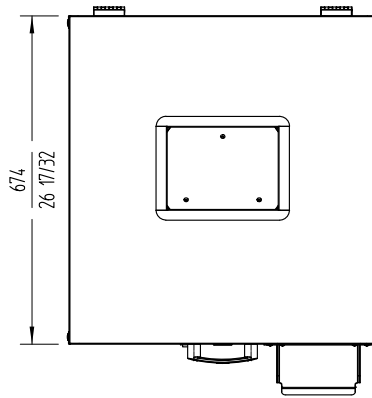
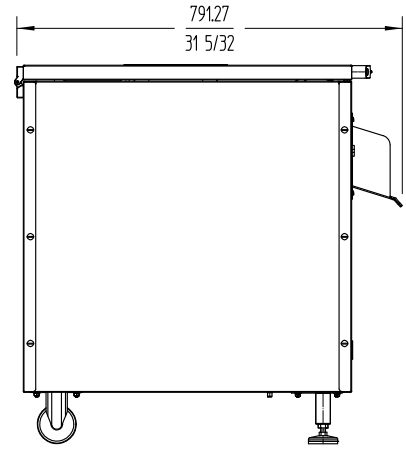
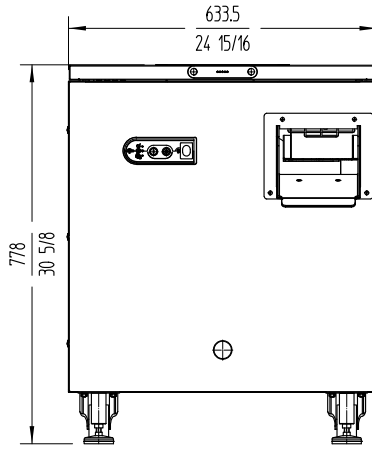

AVAILABLE MODELS

1370041 Cutlery dryer SAS-5001 120/60/1

* Ask for special versions availability

 sammic www.sammic.us Food Service Equipment Manufacturer usa@sammic.com phone +1 (224) 307-2232 1225 Hartrey Avenue toll free +1 844 275 3848 60202-1056 Evanston, IL		Project	Date
		Item	Qty
		Approved	

product sheet
updated 01/11/21