



# Single and Two Door Refrigerators and Freezers

- Electronic thermostat with external digital LED display for accurate control and easy reading.
- Interior cabinet is bright white aluminum liner with full stainless steel floor with coved corners.
- Three adjustable, heavy-duty epoxy coated wire shelves.
- Self-contained capillary tube system using environmentally friendly CFC free refrigerant.
- Exterior cabinet construction consists of full stainless steel front and sides.
- Condensate heating element built into condensate pan for efficient evaporation of excess water.
- Bottom mounted compressor for more efficient operation in coolest area of the kitchen.
- Front accessible, bottom mounted condensing unit is mounted on slide out rack for easy maintenance.
- Easy to mount casters (two lockable) are standard with all units.
- Self-closing doors that remain open at 90 degrees.
- Magnetic door gasket is removable and replaceable without tools.
- Field reversible, lockable door with foamed-in-place recessed handle.
- Larger fan motors and blades for more efficient air flow ensuring faster recovery times.



**AR23**  
**AF23**



**AR49**  
**AF49**

- **Optional Pan Slide Kit (#65100K)**  
You can outfit half of the interior (full interior with two kits) with racks that hold eight standard sheet pans. Fits single door model only.
- **#64900K Sheet Pan Rack**  
Free standing full height rack holds 14 full size sheet pans. Fits all s/s reach-in models.

- Tested to NSF Standard 7 requirements for open food storage.
- Full two year parts and labor warranty and a five year compressor warranty.



**Approved models:**  
**AR23**  
**AR49**  
**AF49**

Model Number	External Dimensions			Doors	Shelves	Cubic Feet	Temperature Range	Cord Length	HP	Amps	NEMA Plug	Crated Weight (lbs.)
	Width	Depth	Height									
<b>AR23</b>	26.75"	32.75"	82.75"	1	3	23	33°F to 41°F	9'	3/8	6	5-15P	320
<b>AF23</b>	26.75"	32.75"	82.75"	1	3	23	-11°F to -1°F	9'	5/8	11	5-15P	335
<b>AR49</b>	54"	32.75"	82.75"	2	6	49	33°F to 41°F	9'	1/2	7	5-15P	470
<b>AF49</b>	54"	32.75"	82.75"	2	6	49	-11°F to -1°F	9'	1	12	5-15P	500

**PHONE** 952-941-2270  
**FAX** 952-941-3066  
**WEB** www.arcticairco.com



# DIMENSIONAL DRAWINGS

Specifications subject to change without notice.

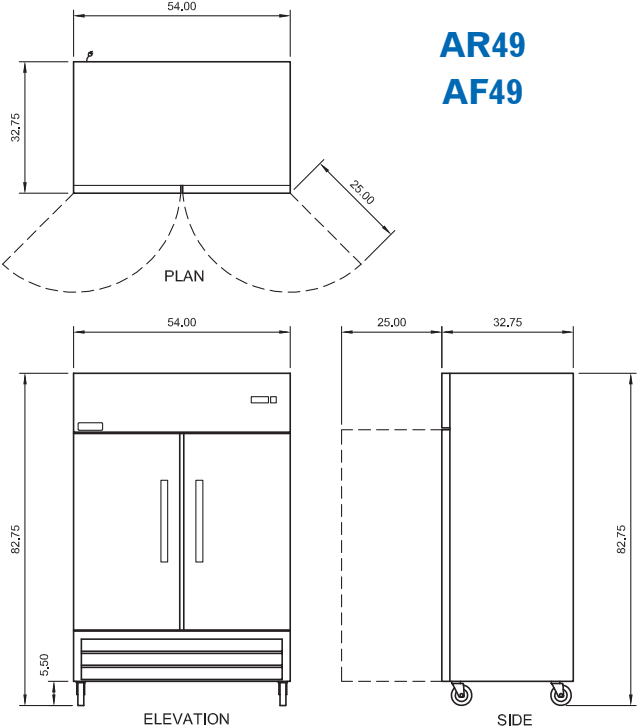
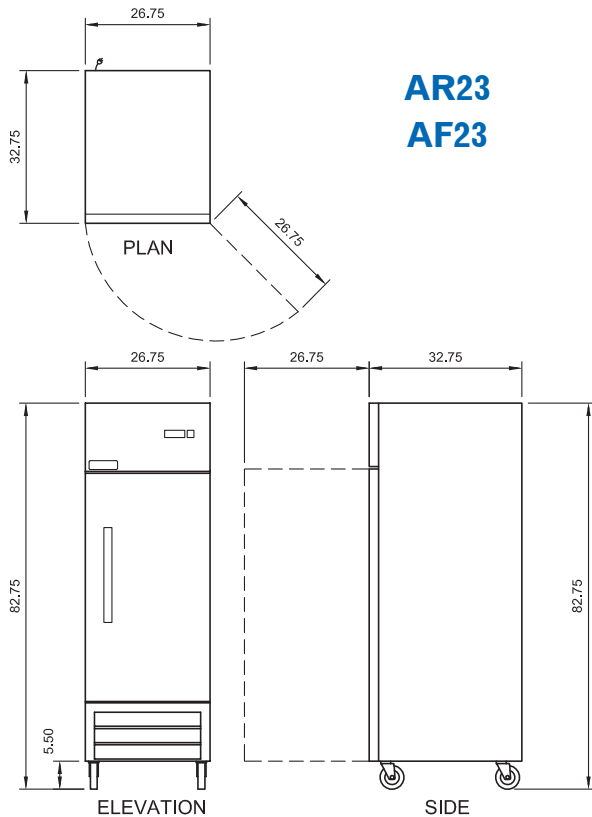

**ARCTIC AIR® — A Division of Broich Enterprises, Inc. — An American Company since 1995**

