

- 1/3 size plastic pans included.
- Full length, heavy-duty cutting board is included.
- Self-closing doors that remain open at 90 degrees.
- Solid door construction with foamed-in-place recessed handle.
- Exterior cabinet construction consists of full stainless steel front and sides.
- Interior cabinet is bright white ABS liner with full stainless steel floor with coved corners.
- Magnetic door gaskets are removable and replaceable without tools.
- Electronic thermostat with external digital LED display for accurate control and easy reading.
- Easy to mount casters (two locking) are standard with all units.
- Tested to NSF Standard 7 requirements for open food storage.
- Full two year parts and labor warranty and a five year compressor warranty.



Model Number	External Dimensions			Doors	Shelves	Pans	Cubic Feet	Temperature Range	Cord Length	HP	Amps	NEMA Plug	Crated Weight (lbs.)
	Width	Depth	Height										
APP48R	47.50"	32.25"	41.00"	1	1	6 (1/3)	12	33°F to 41°F	8'	1/2	7	5-15P	310
	Cutting board depth — 17.75"												
	Total depth with cutting board — 35.25"												
APP71R	71.00"	32.25"	41.00"	2	2	9 (1/3)	21	33°F to 41°F	8'	1/2	7.5	5-15P	410
	Cutting board depth — 17.75"												
	Total depth with cutting board — 35.25"												

PHONE 952-941-2270
FAX 952-941-3066
WEB www.arcticairco.com



DIMENSIONAL DRAWINGS

Specifications subject to change without notice.

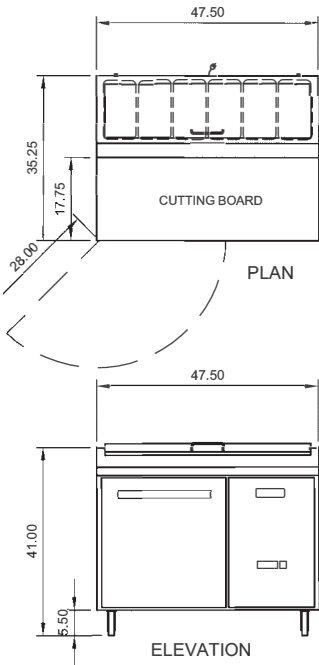

APP48R

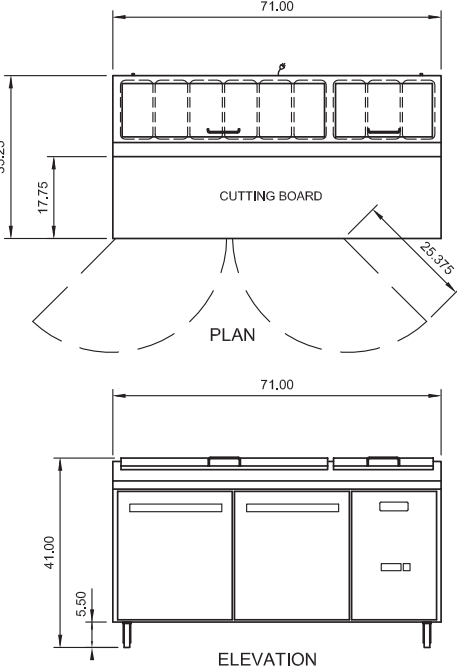
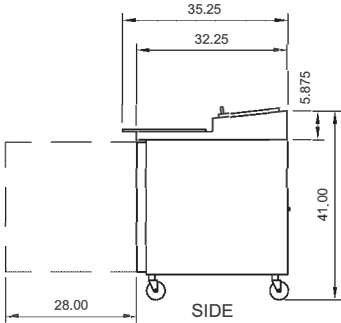

APP71R



ARCTIC AIR® — A Division of Broich Enterprises, Inc. — An American Company since 1995

