

Mega-Top Sandwich/Salad Prep Tables

- Added space allows for extra rows of pans.
- 1/6 size plastic pans included.
- Full length, heavy-duty cutting board is included.
- Self-closing doors that remain open at 90 degrees.
- Solid door construction with foamed-in-place recessed handle.
- Exterior cabinet construction consists of full stainless steel front and sides.
- Interior cabinet is bright white ABS liner with full stainless steel floor with coved corners.
- Magnetic door gaskets are removable and replaceable without tools.
- Electronic thermostat with external digital LED display for accurate control and easy reading.
- Easy to mount casters (two locking) are standard with all units.
- Tested to NSF Standard 7 requirements for open food storage.
- Full two year parts and labor warranty and a five year compressor warranty.



AMT28R



AMT48R



AMT60R

Model Number	External Dimensions			Doors	Shelves	Pans	Cubic Feet	Temperature Range	Cord Length	HP	Amps	NEMA Plug	Crated Weight (lbs.)
	Width	Depth	Height										
AMT28R	29.00"	34.50"	43.30"	1	1	12 (1/6)	6.5	33°F to 41°F	8'	3/8	5	5-15P	230
	Cutting board depth — 9.0"												
AMT48R	48.25"	34.50"	43.30"	2	2	18 (1/6)	12	33°F to 41°F	8'	1/2	7	5-15P	320
	Cutting board depth — 9.0"												
AMT60R	61.25"	34.50"	43.30"	2	2	24 (1/6)	15.5	33°F to 41°F	8'	1/2	7.5	5-15P	385
	Cutting board depth — 9.0"												

PHONE 952-941-2270
FAX 952-941-3066
WEB www.arcticairco.com



DIMENSIONAL DRAWINGS

Specifications subject to change without notice.

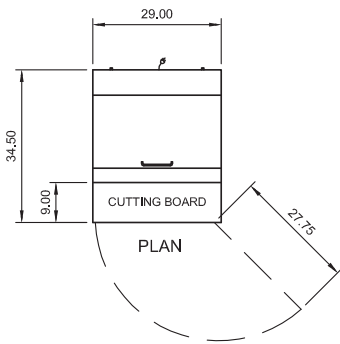

AMT28R

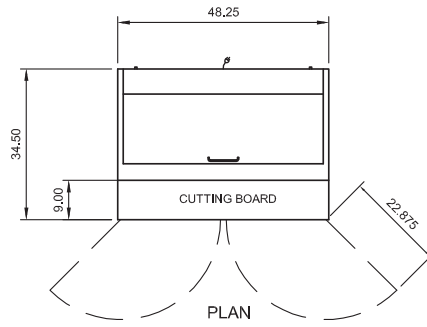

AMT48R

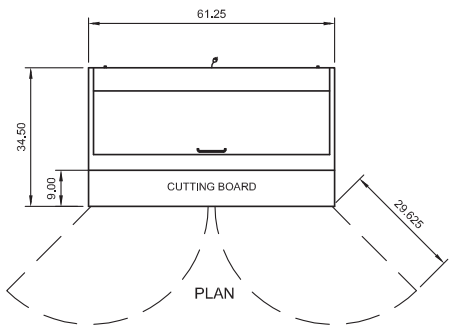
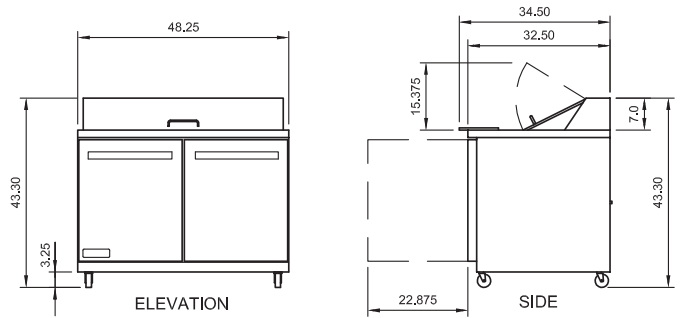
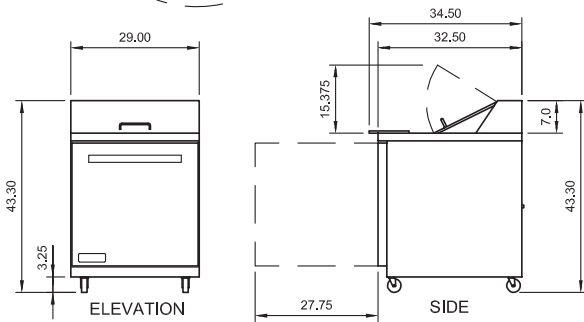

AMT60R

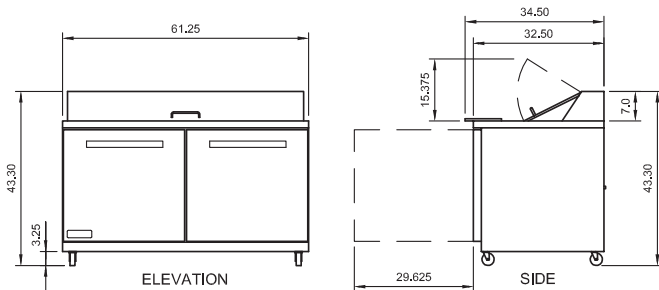

ARCTIC AIR® — A Division of Broich Enterprises, Inc. — An American Company since 1995

