



Single and Two Door Glass Reach-in Refrigerators

- *Electronic thermostat with external digital LED display for accurate control and easy reading.*
- *Interior cabinet is bright stainless liner with full stainless steel floor with coved corners.*
- *Three adjustable, heavy-duty epoxy coated wire shelves.*
- *Self-contained capillary tube system using environmentally friendly CFC free refrigerant.*
- *Exterior cabinet construction consists of full stainless steel front and sides.*
- *Condensate heating element built into condensate pan for efficient evaporation of excess water.*
- *Bottom mounted compressor for more efficient operation in coolest area of the kitchen.*
- *Front accessible, bottom mounted condensing unit is mounted on slide out rack for easy maintenance.*
- *Self-closing lockable doors.*
- *Magnetic door gasket is removable and replaceable without tools.*
- *Larger fan motors and blades for more efficient air flow ensuring faster recovery times.*
- *Easy to mount casters (two lockable) are standard with all units.*
- *Tested to NSF Standard 7 requirements for open food storage.*
- *Full two year parts and labor warranty and a five year compressor warranty.*



AGR23



AGR49

Model Number	External Dimensions			Doors	Shelves	Cubic Feet	Temperature Range	Cord Length	HP	Amps	NEMA Plug	Crated Weight (lbs.)
	Width	Depth	Height									
AGR23	27.0"	31.25"	83.25"	1	3	23	33°F to 50°F	8'	1/3	6	5-15P	330
AGR49	54.0"	31.25"	83.25"	2	6	49	33°F to 50°F	6'	1/2	8	5-15P	500

PHONE 952-941-2270
FAX 952-941-3066
WEB www.arcticairco.com



DIMENSIONAL DRAWINGS

Specifications subject to change without notice.

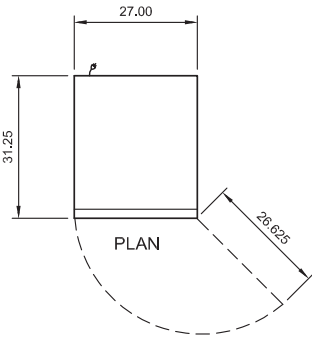

AGR23

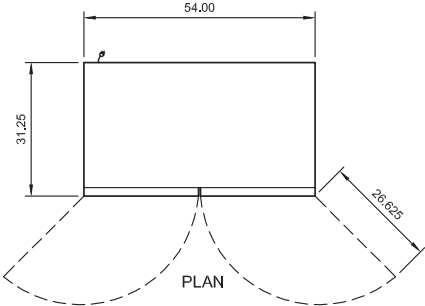

AGR49

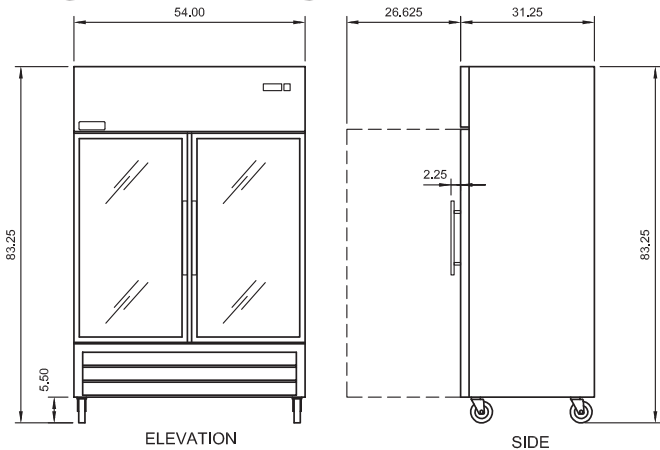
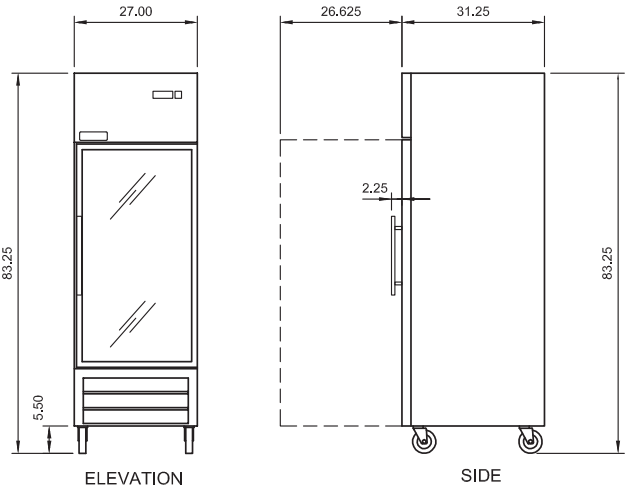

ARCTIC AIR® — A Division of Broich Enterprises, Inc. — An American Company since 1995

