

BACK BAR EQUIPMENT

Product Specifications

BBUC50S-SGD - Undercounter, Shallow Depth Display Cooler with Sliding Glass Doors

Cabinet construction consist of wear resistant, textured baked enamel finish (black) with aluminum top.

All models are front breathing with refrigeration available on left or right.



DIMENSIONAL DATA

| | |
|--|---|
| Net Capacity (cu. ft.) | 13 (368 cu l) |
| Width, Overall (in.) | 50 (1270 mm) |
| Barrel Capacity (# Barrel Type Kegs) | - |
| Straight Wall Capacity (# Straight Wall Kegs) | 2 |
| Depth, Overall (incl. handles & bumpers) (in.) | 22 ⁵ / ₈ (568 mm) |
| Height, Overall (in.) | 34 ¹⁵ / ₁₆ (887 mm) |
| No. of Door(s) | 2 |
| No. of Shelves | 4 |

REFRIGERANT DATA

| | |
|-----------------------------|------|
| Condensing Unit Size (H.P.) | 1/3 |
| Capacity (BTU/Hr)* | 1800 |

ELECTRICAL DATA

| | |
|---------------------------|----------|
| Cabinet | 115/60/1 |
| Feed Wires (incl. ground) | 3 |
| Condensing Unit | 115/60/1 |
| Total Amps | 7.0 |
| Cabinet Amps | 2.4 |

SHIPPING DATA

| | |
|-----------------------|--------------|
| Weight (lbs.) | 365 (166 kg) |
| Height - Crated (in.) | 46 (1168 mm) |
| Width - Crated (in.) | 58 (1473 mm) |
| Depth - Crated (in.) | 42 (1067 mm) |

* Rating @ +25°F evaporator, 90°F ambient
Figures in parentheses reflect metric equivalents.

OPTIONS AND ACCESSORIES

- | | |
|--------------------------------------|---|
| • 6" adjustable legs | • Electric condensate |
| • Locking casters | • Condensing unit on right |
| • Epoxy-coated shelves with clips | • Wine Rack |
| • Stainless steel shelves with clips | • Remote models |
| • Expansion valve system | • Food storage rated stainless steel interior (NSF-7) |
| • Sliding glass door lock | |

Continental
Refrigerator

Toll-Free: 800-523-7138
Phone: 215-244-1400
Fax: 215-244-9579

539 Dunksferry Road
Bensalem, PA 19020
www.continentalrefrigerator.com

Project Name:

Model Specified:

Location:

Item No:

Quantity:

APPROVAL:

Standard Design Features

REFRIGERATION SYSTEM

Environmentally-safe R-134a refrigerant

CABINET ARCHITECTURE

High density, non-CFC polyurethane foam insulation

Wear resistant, textured baked enamel finish (black)

Aluminum top

Heavy-duty galvanized steel interior with reinforced stainless steel floor

Heavy-duty epoxy-coated steel shelves

Double pane, tempered, low-e sliding glass doors

MODEL FEATURES

Front breathing

Easily accessible and serviceable slide-out condensing unit

Automatic, energy-saving, electric condensate evaporator

Front, rear and side venting louvers allow greater condenser air flow for tight fit installations

Flourescent interior lighting

Extra large fin evaporator coil provides uniform air flow distribution to maintain constant product temperature and quick recovery

ELECTRICAL

Completely pre-wired at factory for connection to 115/60/1 phase, 15 amp dedicated outlet

10 ft. cord and plug set included, 90° plug



Equipped with one NEMA-5-15P Plug

BACK BAR EQUIPMENT

BBUC50S-SGD - Undercounter Model Blueprint

Shallow Depth Display with Sliding Glass Doors

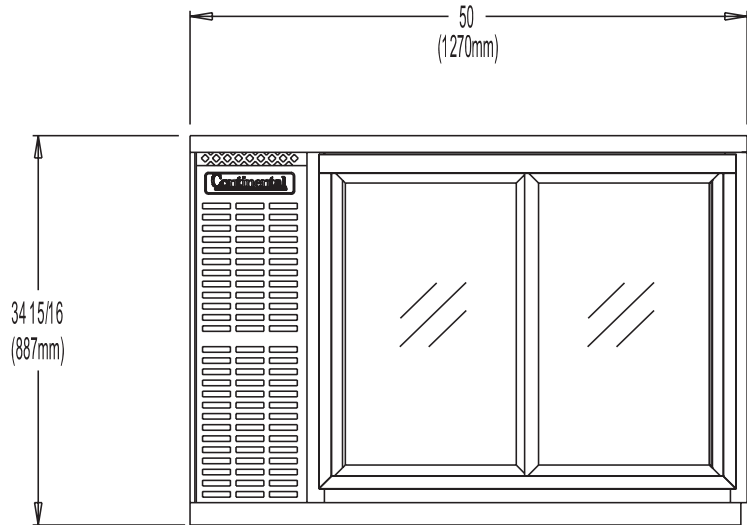

FRONT VIEW

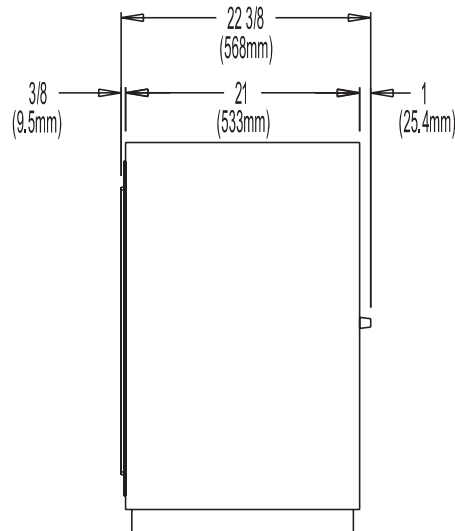

LEFT VIEW



This Continental Refrigerator product is warranted to be free from all manufacturing defects, material or workmanship, for a period of one (1) year from date of original installation, or fifteen (15) months from date of shipment, whichever occurs first. All motor-compressor assemblies are warranted to be free from defects, material and workmanship, for a period of five (5) years from date of installation.

Due to our continued efforts in developing innovative products, specifications subject to change without notice.



© Copyright 2011. Continental Refrigerator.
A Division of National Refrigeration & Air Conditioning Products, Inc.

Continental
Refrigerator

Toll-Free: 800-523-7138
Phone: 215-244-1400
Fax: 215-244-9579

539 Dunksferry Road
Bensalem, PA 19020
www.continentalrefrigerator.com

BBUC50S-SGD (5/10/11)