

BASE MODEL FREEZER (0°F)

Model: CUFA60

60" Undercounter Freezer with Solid Doors

Stainless steel front and end panels, aluminum subtop and interior.

Designed to maintain NSF-7 temperatures in 100°F ambient.



Options and Accessories

(upcharge and lead times may apply)

Drawers in lieu of door (larger section only)	Exterior dial or digital thermometer
Stainless steel pan slides (larger section only)	Stainless steel back and interior
Additional epoxy-coated steel shelves	Condensing unit left or right
Stainless steel shelves	Door locks
Automatic, electric condensate evaporator	Adjustable legs

Project Name:

Model Specified:

Location:

Item No:

Quantity:

AIA #:

SIS #:

Standard Model Features

REFRIGERATION SYSTEM

- Performance-rated **front breathing** refrigeration system
- Environmentally-safe R-404A refrigerant
- Unique forced air design utilizes fans (approx. every 12") across the entire back of unit for even distribution of cold
- Automatic, energy saving, non-electric condensate evaporator
- Non-corrosive, plasticized fin evaporator coil
- Easily serviceable, slide-out condensing unit

CABINET ARCHITECTURE

- 2" non-CFC polyurethane foam insulation
- Spring loaded, self closing doors
- Magnetic snap-in door gaskets
- Heavy-duty, epoxy-coated steel shelves
- 3 5/8" casters
- Completely enclosed, vented and removable rear grill
- Refrigerated door section above the condensing unit

MODEL FEATURES

- Expansion valve for quick recovery
- Automatic electric defrost
- Interior hanging thermometer
- Field rehingeable doors

NOTE: CUFA60 models come standard with a door over the condensing unit, a smaller width door (left section) and larger width door (center section). A drawer over the condensing unit is not available on Undercounter Freezer models. The option of having the door/drawers located in the opposite sections **MUST** be indicated at the time of ordering.

Front breathers are a unique, field assembled, bottom mounted ventilation system designed to allow cabinets to be flush against a wall or built into a counter to conserve space.

Continental
Refrigerator

Toll-Free: 800-523-7138
Phone: 215-244-1400
Fax: 215-244-9579

539 Dunksferry Road
Bensalem, PA 19020
www.continentalrefrigerator.com

APPROVAL:

Model Specifications

DIMENSIONAL DATA

Net Capacity (cu. ft.)	19 (538 cu l)
Width, Overall (in.)	60 3/16 (1529 mm)
Depth, Overall (in.) (incl. handles & bumpers)	36 1/16 (916 mm)
Height, Overall (in.) (incl. 3 5/8" casters)	31 13/16 (808 mm)
Shelf Area (sq. ft.)	7.1 (.7 sq m)
No. of Shelves	4
No. of Full Doors	2
No. of Half Doors	1
Interior Depth (in.)	30 (762 mm)
Interior Height (in.)	26 (660 mm)
Interior Height (in.) (above condenser)	12 1/2 (318 mm)
Interior Width (in.)	56 (1422 mm)

REFRIGERANT DATA

Condensing Unit Size (H.P.)	1/2
Capacity (BTU/Hr)*	2180

ELECTRICAL DATA

Voltage (int'l)	115/60/1 (220/50/1)
Fans	3
Total Amps (int'l)	10.0 (4.6)
10 ft. Cord/Plug [attached] (int'l)	Yes (No)

SHIPPING DATA

Weight (lbs.)	410 (186 kg)
Height - Crated (in.)	43 3/4 (1111 mm)
Width - Crated (in.)	62 (1575 mm)
Depth - Crated (in.)	47 (1194 mm)

* Rating @ -15°F evaporator, 90°F ambient

Figures in parentheses reflect metric equivalents rounded to the nearest whole unit.



Equipped with one NEMA-5-15P Plug
(varies by country)

Model Plan Views

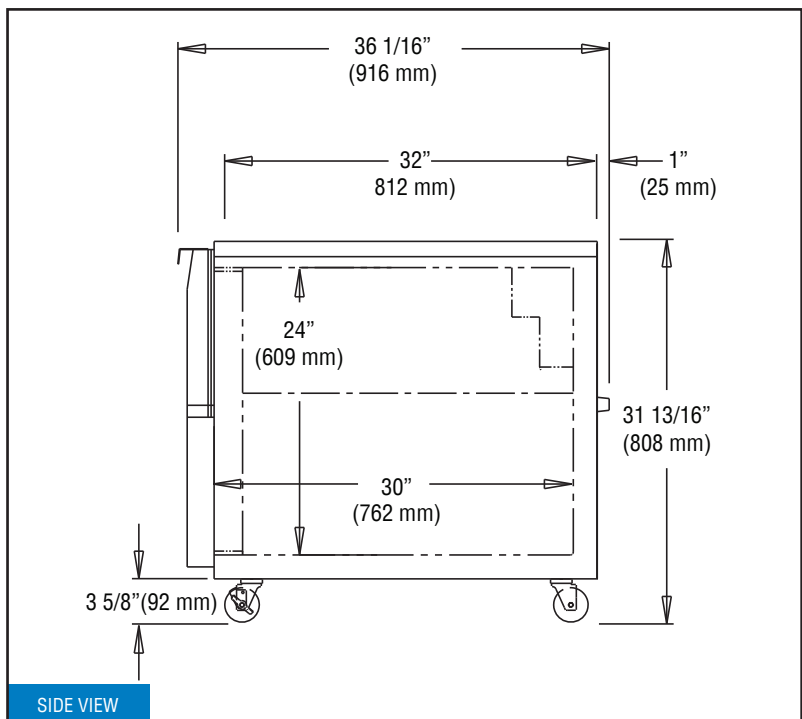
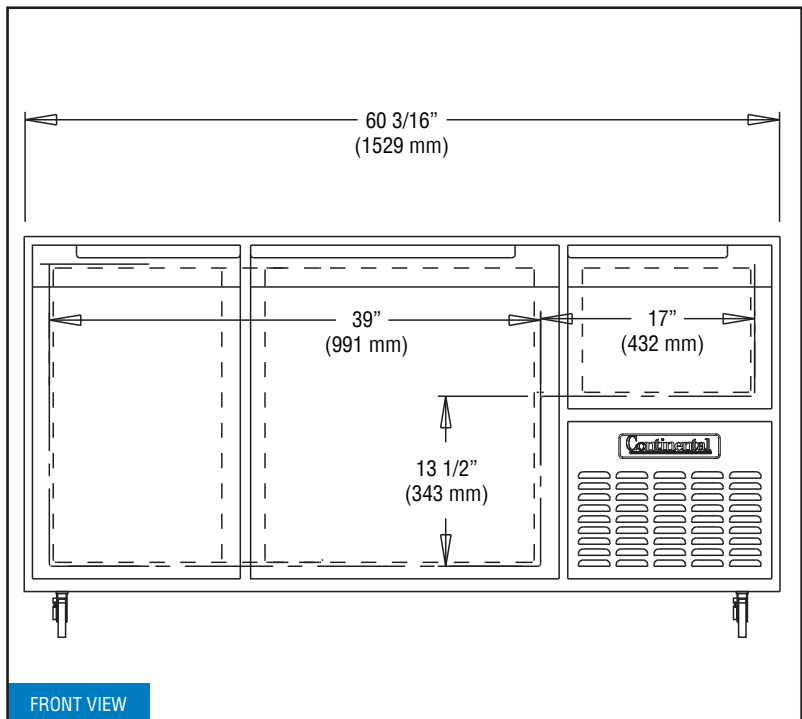

Continental
Refrigerator

Toll-Free: 800-523-7138
Phone: 215-244-1400
Fax: 215-244-9579

539 Dunkserry Road
Bensalem, PA 19020
www.continentalrefrigerator.com

Due to our continued efforts in developing innovative products, specifications subject to change without notice.



MADE IN THE U.S.A.

© Copyright 2016. Continental Refrigerator.
A Division of National Refrigeration & Air Conditioning Products, Inc.