

BASE MODEL FREEZER (0°F)

Model: CUFA68

68" Undercounter Freezer with Solid Doors

Stainless steel front and end panels, aluminum subtop and interior.

Designed to maintain NSF-7 temperatures in 100°F ambient.



Options and Accessories

(upcharge and lead times may apply)

Drawers in lieu of doors (full door sections only)	Exterior dial or digital thermometer
Additional epoxy-coated steel shelves	Condensing unit left or right
Stainless steel shelves	Stainless steel pan slides
Automatic, electric condensate evaporator	Door locks
Stainless steel back and interior	Adjustable legs

Project Name:

Model Specified:

Location:

Item No:

Quantity:

AIA #:

SIS #:

Standard Model Features

REFRIGERATION SYSTEM

- Performance-rated **front breathing** refrigeration system
- Environmentally-safe R-404A refrigerant
- Unique forced air design utilizes fans (approx. every 12") across the entire back of unit for even distribution of cold
- Automatic, energy saving, non-electric condensate evaporator
- Non-corrosive, plasticized fin evaporator coil
- Easily serviceable, slide-out condensing unit

CABINET ARCHITECTURE

- 2" non-CFC polyurethane foam insulation
- Spring loaded, self closing doors
- Magnetic snap-in door gaskets
- Heavy-duty, epoxy-coated steel shelves
- 3 5/8" casters
- Completely enclosed, vented and removable rear grill
- Refrigerated door section above the condensing unit

MODEL FEATURES

- Expansion valve for quick recovery
- Automatic electric defrost
- Interior hanging thermometer
- Field rehingable doors

NOTE: CUFA models come standard with a door over the condensing unit. A drawer over the condensing unit is not available on Undercounter Freezer models.

Front breathers are a unique, field assembled, bottom mounted ventilation system designed to allow cabinets to be flush against a wall or built into a counter to conserve space.

Continental[®]
Refrigerator

Toll-Free: 800-523-7138
Phone: 215-244-1400
Fax: 215-244-9579

539 Dunksferry Road
Bensalem, PA 19020
www.continentalrefrigerator.com

APPROVAL:

Model Specifications

DIMENSIONAL DATA

Net Capacity (cu. ft.)	22 (623 cu l)
Width, Overall (in.)	68 3/16 (1732 mm)
Depth, Overall (in.) (incl. handles & bumpers)	36 1/16 (916 mm)
Height, Overall (in.) (incl. 3 5/8" casters)	31 13/16 (808 mm)
Shelf Area (sq. ft.)	9.8 (.9 sq m)
No. of Shelves	4
No. of Full Doors	2
No. of Half Doors	1
Interior Depth (in.)	30 (762 mm)
Interior Height (in.)	26 (660 mm)
Interior Height (in.) (above condenser)	12 1/2 (318 mm)
Interior Width (in.)	64 (1626 mm)

REFRIGERANT DATA

Condensing Unit Size (H.P.)	1/2
Capacity (BTU/Hr)*	2310

ELECTRICAL DATA

Voltage (int'l)	115/60/1 (220/50/1)
Fans	4
Total Amps (int'l)	10.7 (4.9)
10 ft. Cord/Plug [attached] (int'l)	Yes (No)

SHIPPING DATA

Weight (lbs.)	490 (222 kg)
Height - Crated (in.)	43 3/4 (1111 mm)
Width - Crated (in.)	70 (1778 mm)
Depth - Crated (in.)	47 (1194 mm)

* Rating @ -15°F evaporator, 90°F ambient

Figures in parentheses reflect metric equivalents rounded to the nearest whole unit.



Equipped with one NEMA-5-15P Plug
(varies by country)

Model Plan Views

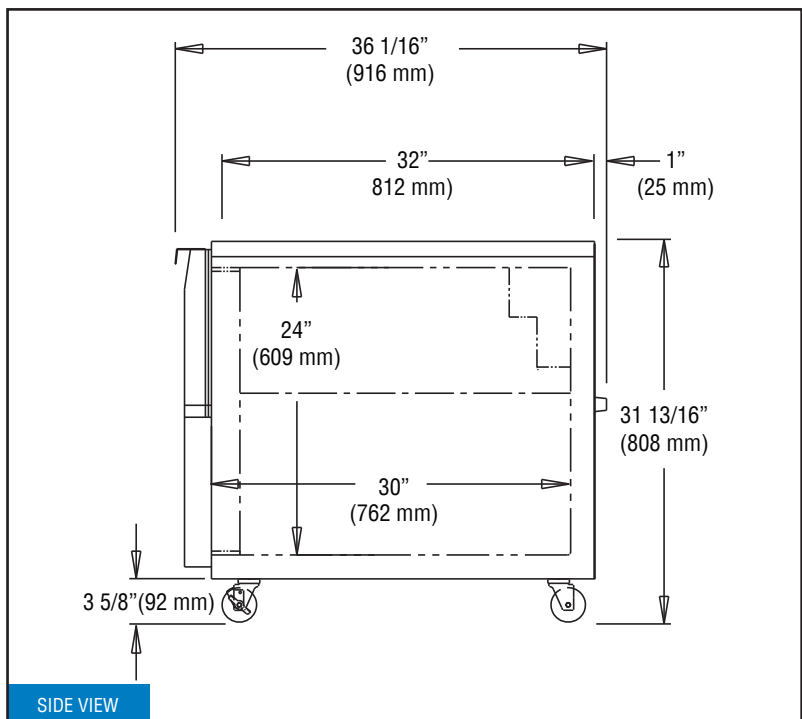
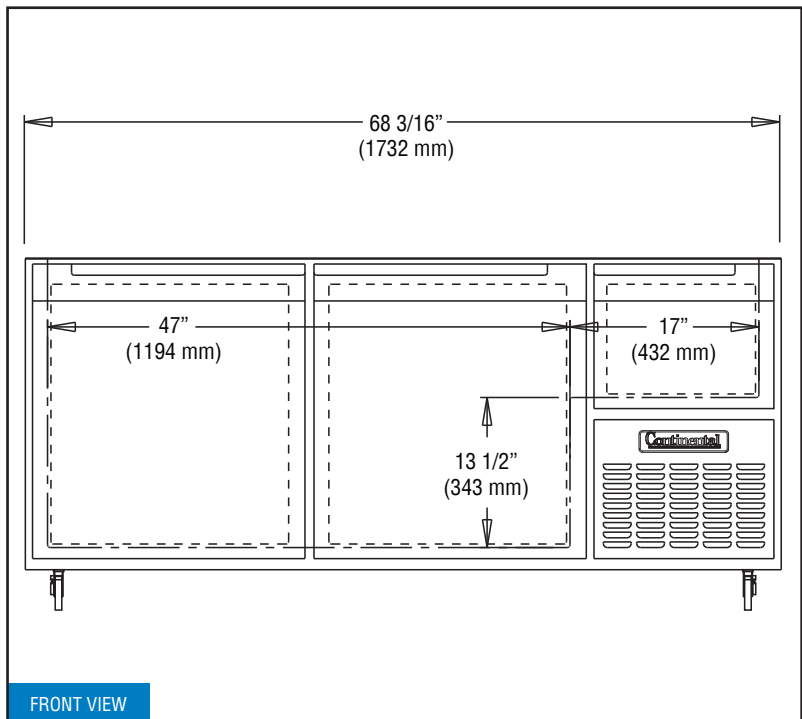

Continental
Refrigerator

Toll-Free: 800-523-7138
Phone: 215-244-1400
Fax: 215-244-9579

539 Dunkserry Road
Bensalem, PA 19020
www.continentalrefrigerator.com

Due to our continued efforts in developing innovative products, specifications subject to change without notice.



MADE IN THE U.S.A.

© Copyright 2016. Continental Refrigerator.
A Division of National Refrigeration & Air Conditioning Products, Inc.