

# BASE MODEL REFRIGERATOR

## Model: CURA118-D

### 118" Undercounter Refrigerator with Drawers

Stainless steel front and end panels, aluminum subtop and interior.

Designed to maintain NSF-7 temperatures in 100°F ambient.



#### Options and Accessories

(upcharge and lead times may apply)

Door in lieu of drawers	Stainless steel back and interior
Drawer section above the condensing unit*	Condensing unit left or right
Automatic, electric condensate evaporator	Door/drawer locks
Exterior dial or digital thermometer	Adjustable legs

\*Drawer section above condensing unit holds (1) 12 x 20 x 6 pan

Project Name:

Model Specified:

Location:

Item No:

Quantity:

AIA #:

SIS #:

#### Standard Model Features

##### REFRIGERATION SYSTEM

- Performance-rated front breathing refrigeration system
- Environmentally-safe R-134a refrigerant
- Unique forced air design utilizes fans (approx. every 12") across the entire back of unit for even distribution of cold
- Automatic, energy saving, non-electric condensate evaporator
- Non-corrosive, plasticized fin evaporator coil
- Easily serviceable, slide-out condensing unit

##### CABINET ARCHITECTURE

- 2" non-CFC polyurethane foam insulation
- Spring loaded, self closing door (over condensing unit)
- Magnetic snap-in door/drawer gaskets
- Stainless steel roll-out drawers
- 3 5/8" casters
- Completely enclosed, vented and removable rear grill
- Refrigerated door section above the condensing unit

##### MODEL FEATURES

- Expansion valve for quick recovery
- Built-in, off cycle defrost timer
- Interior hanging thermometer
- Field rehingeable door (over condensing unit)

**NOTE:** CURA-D models come standard with a door over the condensing unit. A drawer over the condensing unit is an option.

Front breathers are a unique, field assembled, bottom mounted ventilation system designed to allow cabinets to be flush against a wall or built into a counter to conserve space.

**Continental**  
Refrigerator

Toll-Free: 800-523-7138  
Phone: 215-244-1400  
Fax: 215-244-9579

539 Dunksferry Road  
Bensalem, PA 19020  
www.continentalrefrigerator.com

APPROVAL:

## Model Specifications

### DIMENSIONAL DATA

Net Capacity (cu. ft.)	44 (1246 cu l)
Width, Overall (in.)	118 3/16 (3002 mm)
Depth, Overall (in.) (incl. handles & bumpers)	36 1/16 (916 mm)
Height, Overall (in.) (incl. 3 5/8" casters)	31 13/16 (808 mm)
No. of Drawers	8
No. of Half Doors	1
Interior Depth (in.) (above condenser)	30 (762 mm)
Interior Height (in.) (above condenser)	12 1/2 (318 mm)
Interior Width (in.) (above condenser)	17 (432 mm)

### REFRIGERANT DATA

Condensing Unit Size (H.P.)	1/2
Capacity (BTU/Hr)*	5600

### ELECTRICAL DATA

Voltage (int'l)	115/60/1 (220/50/1)
Fans	6
Total Amps (int'l)	15.2 (n/a)
10 ft. Cord/Plug [attached] (int'l)	Yes (No)

### SHIPPING DATA

Weight (lbs.)	705 (320 kg)
Height - Crated (in.)	43 3/4 (1111 mm)
Width - Crated (in.)	120 (3048 mm)
Depth - Crated (in.)	47 (1194 mm)

### DRAWER PAN CONFIGURATIONS

**Two Tier:** (2) 12 x 20 x 4 pans (top)  
and (2) 12 x 20 x 6 pans (bottom)

**Three Tier:** (1) 12 x 20 x 4 pan (top)  
and (2) 12 x 20 x 4 pans per drawer (center & bottom)

\* Rating @ +25°F evaporator, 90°F ambient

Figures in parentheses reflect metric equivalents rounded to the nearest whole unit.



Equipped with one NEMA-5-15P Plug  
(varies by country)

## Model Plan Views

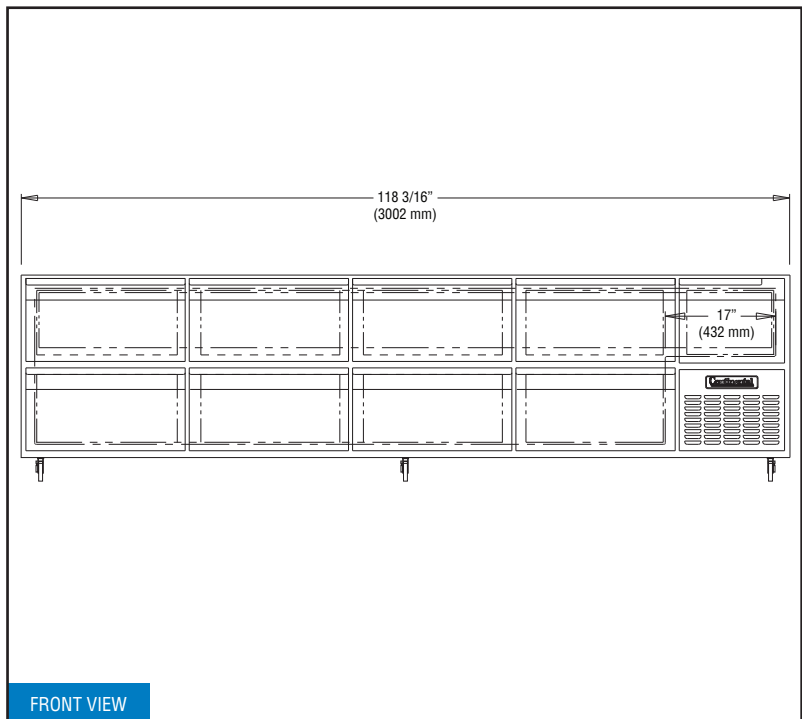

FRONT VIEW

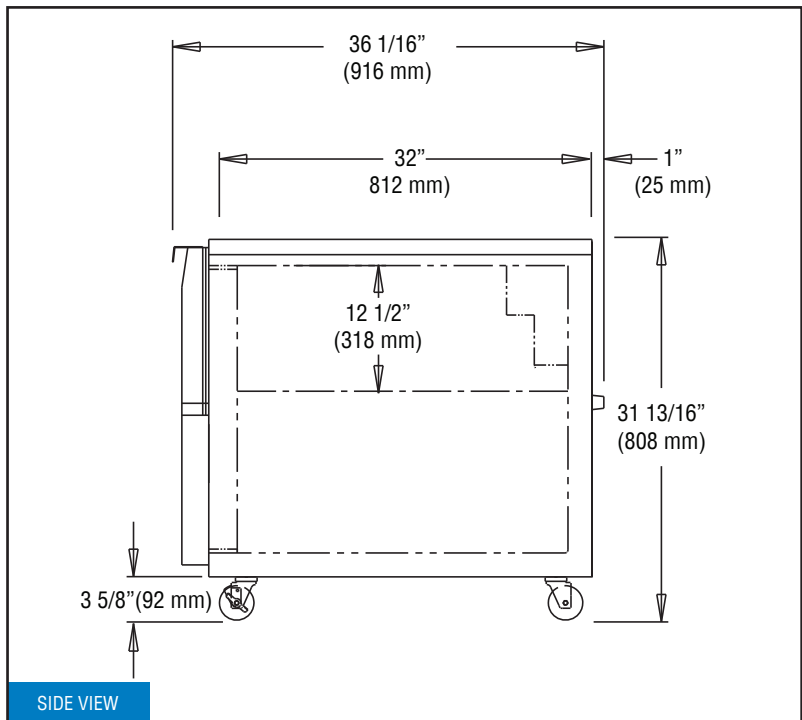

SIDE VIEW

**Continental**  
Refrigerator

Toll-Free: 800-523-7138  
Phone: 215-244-1400  
Fax: 215-244-9579

539 Dunkserry Road  
Bensalem, PA 19020  
[www.continentalrefrigerator.com](http://www.continentalrefrigerator.com)

Due to our continued efforts in developing innovative products, specifications subject to change without notice.



MADE IN THE U.S.A.

© Copyright 2016. Continental Refrigerator.  
A Division of National Refrigeration & Air Conditioning Products, Inc.