

SANDWICH UNIT REFRIGERATOR

Model: SW60-24M-HGL-FB-D

60" Mighty Top Sandwich Unit
with Drawers and Hinged Glass Lid
24 Pans - Front Breathing

Stainless steel front and top, aluminum end panels, case back and interior.
**Certified under NSF-7 to maintain temperatures in 86°F ambient
and designed to maintain NSF-7 temperatures in 100°F ambient.**



Options and Accessories

(upcharge and lead times may apply)

Stainless steel exterior and interior - SS models	Rear-mounted cutting board
Stainless steel end panels - SA models	Remote models
Glass doors in lieu of drawers - GD models	Drawer locks
Stainless steel finished back in lieu of aluminum	Adjustable legs
Solid doors in lieu of drawers	Digital thermometer
Automatic, electric condensate evaporator	Crumb catcher
Expansion valve system	Three tier drawers

Consult factory for other model configurations, options and accessories.

Continental
Refrigerator

Toll-Free: 800-523-7138
Phone: 215-244-1400
Fax: 215-244-9579

539 Dunksferry Road
Bensalem, PA 19020
www.continentalrefrigerator.com

Project Name:

Model Specified:

Location:

Item No:

Quantity:

AIA #:

SIS #:

Standard Model Features

REFRIGERATION SYSTEM

- Performance-rated refrigeration system
- Environmentally-safe R-134a refrigerant
- Unique air flow distribution allows pan product to maintain 33° - 41°F
- Automatic, energy saving, non-electric condensate evaporator
- Non-corrosive, plasticized fin evaporator coil
- Easily serviceable, back mounted compressor

CABINET ARCHITECTURE

- 2" non-CFC polyurethane foam insulation
- Magnetic snap-in drawer gaskets
- 8" deep, full length nylon cutting board
- Stainless steel roll-out drawers
- 3 5/8" casters
- Completely enclosed, vented and removable case back
- Energy-efficient, 2-pane, Low-E glass lid
- Aluminum glass frame with satin finish
- Concealed lid hinges
- Integral stainless steel gas spring lid supports

MODEL FEATURES

- (24) 1/6 size non-recessed pans, 4" deep
- Interior hanging thermometer

Front breathers are a unique, field assembled, bottom mounted ventilation system designed to allow cabinets to be flush against a wall or built into a counter to conserve space.

APPROVAL:

Model Specifications

DIMENSIONAL DATA

Net Capacity (cu. ft.)	17.0 (481 cu l)
1/6 Size Pans (4" deep)	24
Width, Overall (in.)	60 (1524 mm)
Depth, Overall (in.) (incl. handles & bumpers)	35 (889 mm)
Depth, Body Only (less drawers) (in.)	27 1/2 (699 mm)
Depth, Cutting Board (in.)	8 (203 mm)
Height, Overall (in.) (incl. 3 5/8" casters)	35 5/8 (905 mm)
No. of Drawers (two tier)	4
No. of Drawers (three tier)	6

REFRIGERANT DATA

Condensing Unit Size (H.P.)	1/4
Capacity (BTU/Hr)*	1940

ELECTRICAL DATA

Voltage (int'l)	115/60/1 (220/50/1)
Fans	3
Total Amps (int'l)	6.6 (4.4)
10 ft. Cord/Plug [attached] (int'l)	Yes (No)

SHIPPING DATA

Weight (lbs.)	368 (167 kg)
Height - Crated (in.)	43 1/4 (1099 mm)
Width - Crated (in.)	68 1/4 (1734 mm)
Depth - Crated (in.)	46 (1168 mm)

DRAWER PAN CONFIGURATIONS

Two Tier: (1) 12 x 20 x 6 pan per drawer

Three Tier: (1) 12 x 20 x 4 pan per drawer

* Rating @ +25°F evaporator, 90°F ambient

Figures in parentheses reflect metric equivalents rounded to the nearest whole unit.



Equipped with one NEMA-5-15P Plug
(varies by country)

Continental

Refrigerator

Toll-Free: 800-523-7138
Phone: 215-244-1400
Fax: 215-244-9579

539 Dunkserry Road
Bensalem, PA 19020
www.continentalrefrigerator.com

Due to our continued efforts in developing innovative products, specifications subject to change without notice.



© Copyright 2014. Continental Refrigerator.
A Division of National Refrigeration & Air Conditioning Products, Inc.

Model Plan Views

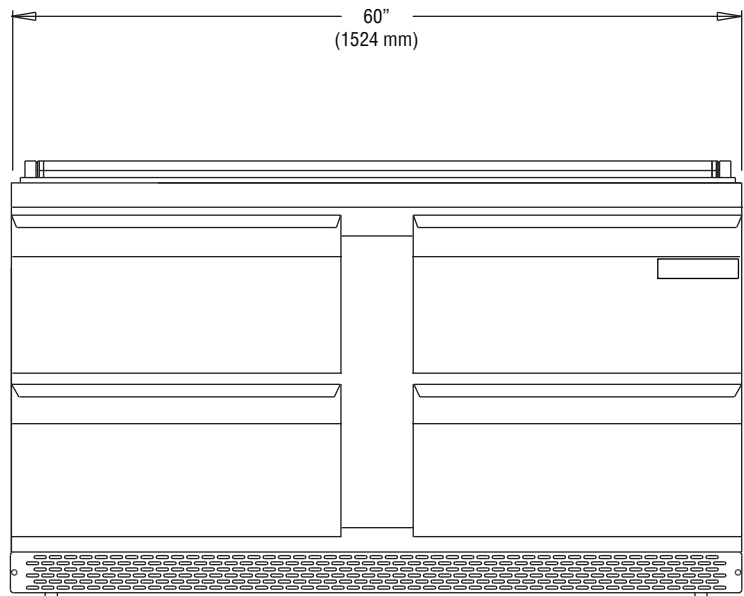

FRONT VIEW

Note: Shown with two tier drawers.

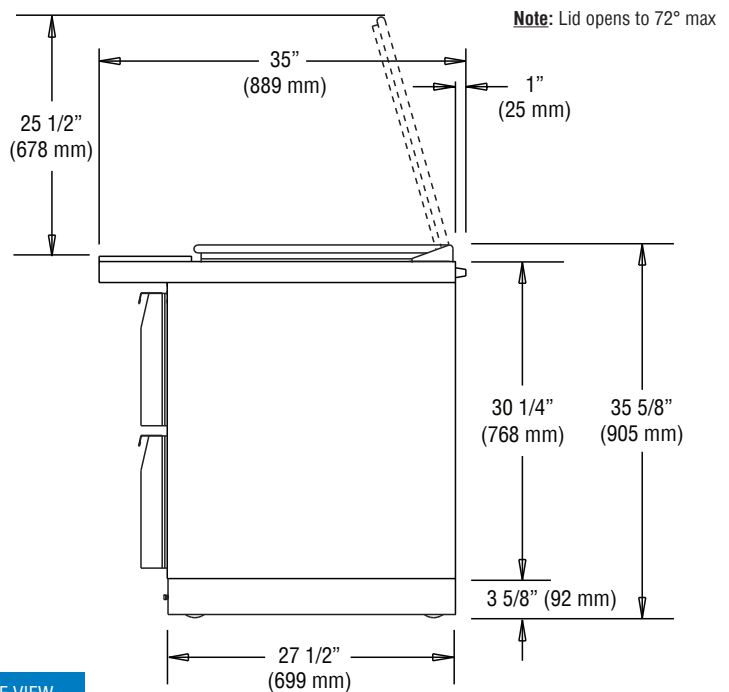

SIDE VIEW

Note: Lid opens to 72° max

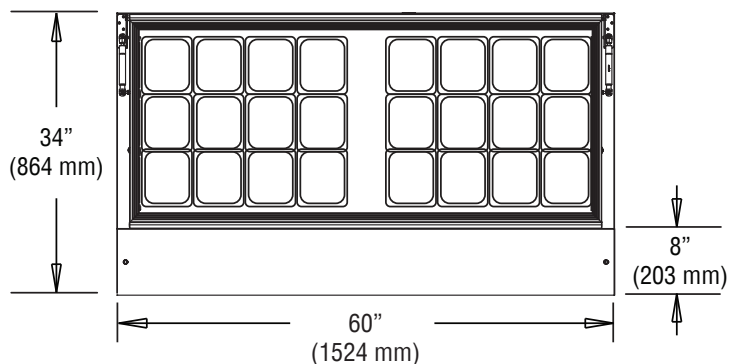

PAN TOP CONFIGURATION