

# PIZZA PREPARATION TABLE

**Model: CPA93**

## 93" Pizza Preparation Refrigerator with Solid Doors

Heavy gauge #300 Series stainless steel top, stainless steel front and end panels, galvanized steel rear and grill and aluminum interior.  
**Certified under NSF-7 to maintain temperatures in 86°F ambient and designed to maintain NSF-7 temperatures in 100°F ambient.**



### Options and Accessories

(upcharge and lead times may apply)

Drawers in lieu of doors	Condensing unit left or right
Drawer section above the condensing unit*	Stainless steel pan slides
Overshelves (single or double)	Wire rod garnish rack
Additional epoxy-coated steel shelves	Door locks
Automatic, electric condensate evaporator	Adjustable legs
Exterior dial or digital thermometer	Front breathing
Stainless steel back and interior	

\*Drawer section above condensing unit holds (1) 12 x 20 x 6 pan

Project Name:

Model Specified:

Location:

Item No:

Quantity:

AIA #:

SIS #:

### Standard Model Features

#### REFRIGERATION SYSTEM

Performance-rated refrigeration system

Environmentally-safe R-134a refrigerant

Unique forced air design utilizes fans (approx. every 12") across the entire back of unit for even distribution of cold

Automatic, energy saving, non-electric condensate evaporator

Non-corrosive, plasticized fin evaporator coil

Easily serviceable, slide-out condensing unit

#### CABINET ARCHITECTURE

2" non-CFC polyurethane foam insulation

Spring loaded, self closing doors

Magnetic snap-in door gaskets

Heavy-duty, epoxy-coated steel shelves

19" deep, full length nylon cutting board

Insulated lid

5" casters

Refrigerated door section above the condensing unit

#### MODEL FEATURES

"Ergonomically-friendly" raised angle rail

Expansion valve for quick recovery

Built-in, off cycle defrost timer

Interior hanging thermometer

Field rehingeable doors

**NOTE:** CPA models come standard with a door over the condensing unit. A drawer over the condensing unit is an option.

**Continental**  
 Refrigerator

Toll-Free: 800-523-7138  
 Phone: 215-244-1400  
 Fax: 215-244-9579

539 Dunksferry Road  
 Bensalem, PA 19020  
[www.continentalrefrigerator.com](http://www.continentalrefrigerator.com)

APPROVAL:

## Model Specifications

### DIMENSIONAL DATA

Net Capacity (cu. ft.)	32 (906 cu l)
Width, Overall (in.)	93 (2362 mm)
Depth, Overall (in.) (incl. handles & bumpers)	36 7/8 (937 mm)
Height, Overall (in.) (incl. 5" casters)	39 7/16 (1002 mm)
Depth, Cutting Board (in.)	19 (483 mm)
Pan Capacity (pans supplied by others)	(12) 1/3
Shelf Area (sq. ft.)	14.2 (1.3 sq m)
No. of Shelves	3
No. of Full Doors	3
No. of Half Doors	1
Interior Depth (in.)	27 3/8 (695 mm)
Interior Height (in.)	26 (660 mm)
Interior Height (in.) (above condenser)	12 1/2 (318 mm)
Interior Width (in.)	89 (2261 mm)

### REFRIGERANT DATA

Condensing Unit Size (H.P.)	1/2
Capacity (BTU/Hr)*	5260

### ELECTRICAL DATA

Voltage (int'l)	115/60/1 (220/50/1)
Fans	6
Total Amps (int'l)	14.4 (9.1)
10 ft. Cord/Plug [attached] (int'l)	Yes (No)

### SHIPPING DATA

Weight (lbs.)	605 (274 kg)
Height - Crated (in.)	43 3/4 (1111 mm)
Width - Crated (in.)	95 (2413 mm)
Depth - Crated (in.)	47 (1194 mm)

\* Rating @ +25°F evaporator, 90°F ambient

Figures in parentheses reflect metric equivalents rounded to the nearest whole unit.



Equipped with one NEMA-5-15P Plug  
(varies by country)

## Model Plan Views

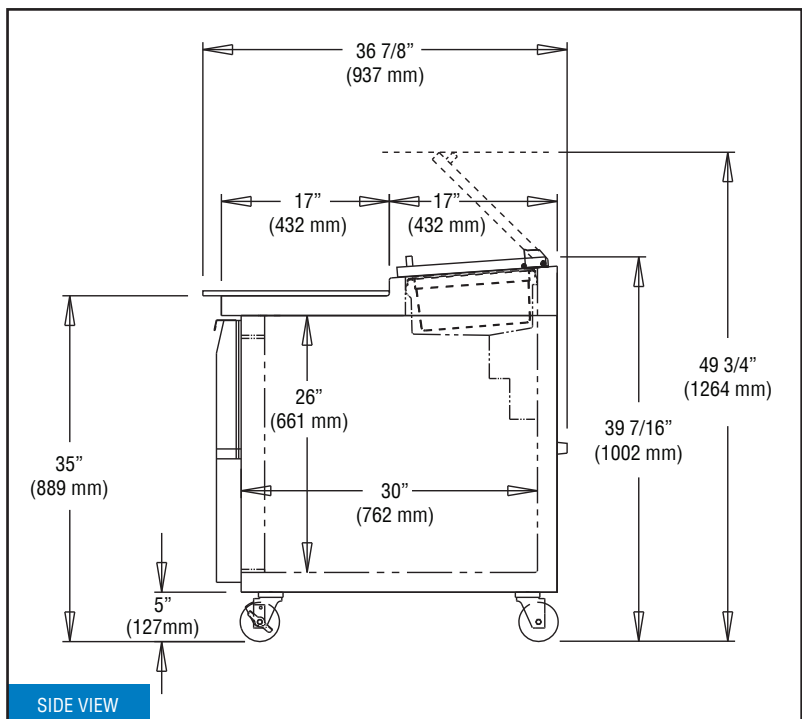
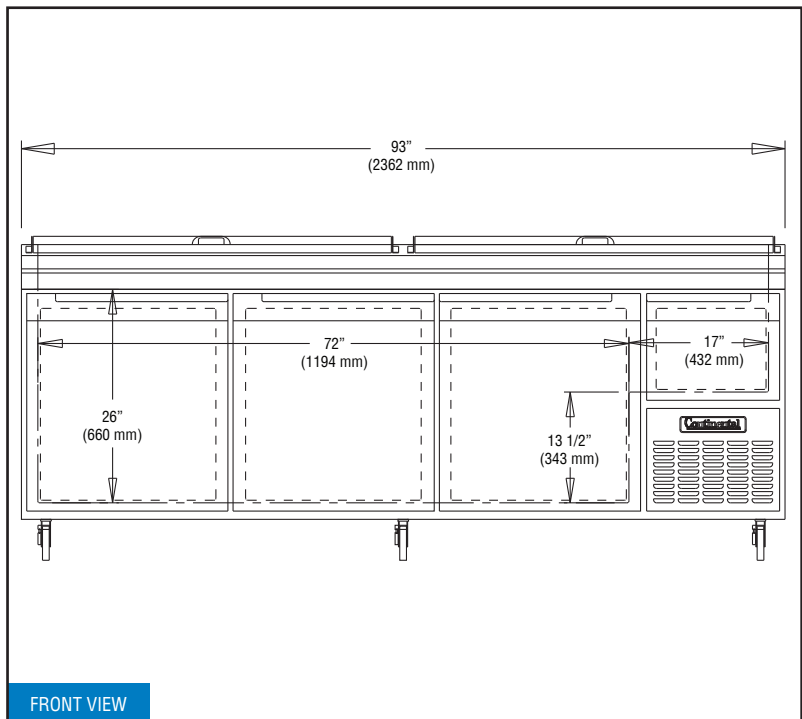

**Continental**  
Refrigerator

Toll-Free: 800-523-7138  
Phone: 215-244-1400  
Fax: 215-244-9579

539 Dunkserry Road  
Bensalem, PA 19020  
[www.continentalrefrigerator.com](http://www.continentalrefrigerator.com)

Due to our continued efforts in developing innovative products, specifications subject to change without notice.



MADE IN THE U.S.A.

© Copyright 2016. Continental Refrigerator.  
A Division of National Refrigeration & Air Conditioning Products, Inc.