

GLASS & PLATE CHILLER (0°F)

Model: CGC37-SS

37" Glass & Plate Chiller

Stainless steel exterior with all stainless steel countertop and slide lid, heavy-duty galvanized interior.

Designed to maintain NSF-7 temperatures in 100°F ambient.



Options and Accessories

(upcharge and lead times may apply)

Textured baked enamel finish exterior (black)	Lid lock
Stainless steel interior	Casters
Additional epoxy-coated, steel wire shelves	Adjustable legs
Automatic, electric condensate evaporator	

Consult factory for other model configurations, options and accessories.

Continental
Refrigerator

Toll-Free: 800-523-7138
Phone: 215-244-1400
Fax: 215-244-9579

539 Dunksferry Road
Bensalem, PA 19020
www.continentalrefrigerator.com

Project Name:

Model Specified:

Location:

Item No:

Quantity:

AIA #:

SIS #:

Standard Model Features

REFRIGERATION SYSTEM

Environmentally-safe R-404A refrigerant

Performance-rated refrigeration system

Full length, extra large coil for quick top row product chilling

Easily accessible and serviceable slide-out condensing unit

CABINET ARCHITECTURE

High density, non-CFC polyurethane foamed-in-place insulation

Heavy-duty sliding shelves

Front, rear and side venting louvered panels

MODEL FEATURES

Automatic time defrosting period is timer initiated and temperature terminated with automatic, energy-saving, non-electric condensate evaporator

Cabinet will maintain 0°F for fast frosting of wet or dry glasses

Expansion valve system

Electronic controller w/ digital display

APPROVAL:

Model Specifications

DIMENSIONAL DATA

Net Capacity (cu. ft.)	10.3 (292 cu l)
5" Mug Capacity (# mugs)	180
Stein Capacity (# 10 oz. steins)	170
Width, Overall (in.)	37 (940 mm)
Depth, Overall (in.) (incl. bumpers)	28 1/2 (724 mm)
Height, Overall (in.)	33 1/2 (851 mm)
No. of Slide Lids	1
No. of Shelves	2

REFRIGERANT DATA

Condensing Unit Size (H.P.)	1/3
Capacity (BTU/Hr)*	1130

ELECTRICAL DATA

Voltage (int'l)	115/60/1 (220/50/1)
Feed Wires (incl. ground)	3
Total Amps (int'l)	6.1 (3.2)
10 ft. Cord/Plug [attached] (int'l)	Yes (No)

SHIPPING DATA

Weight - (lbs.)	245 (111 kg)
Height - Crated (in.)	39 (991 mm)
Width - Crated (in.)	46 (1168 mm)
Depth - Crated (in.)	30 1/4 (768 mm)

* Rating @ -15°F evaporator, 90°F ambient

Figures in parentheses reflect metric equivalents rounded to the nearest whole unit.



Equipped with one NEMA-5-15P Plug
(varies by country)

Model Plan Views

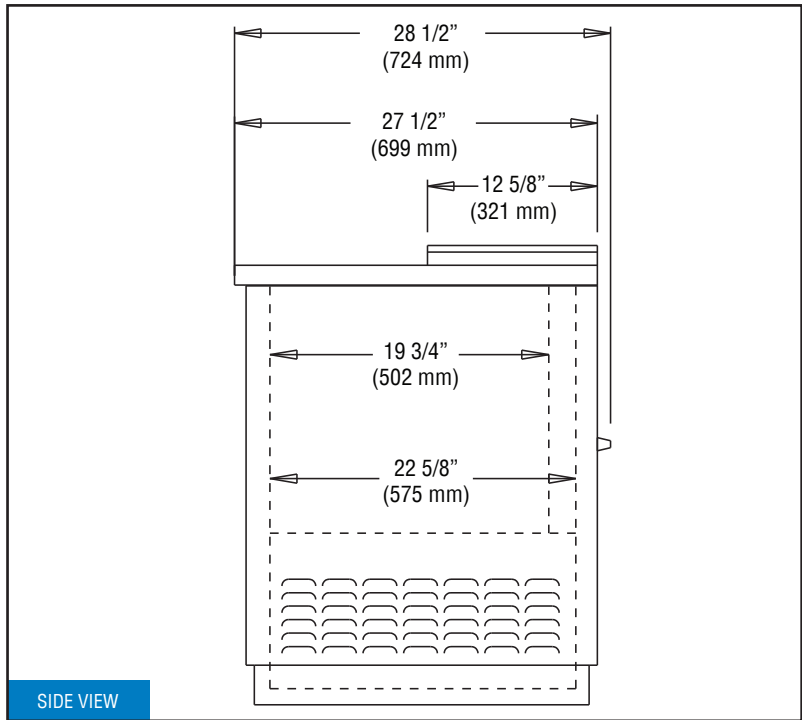
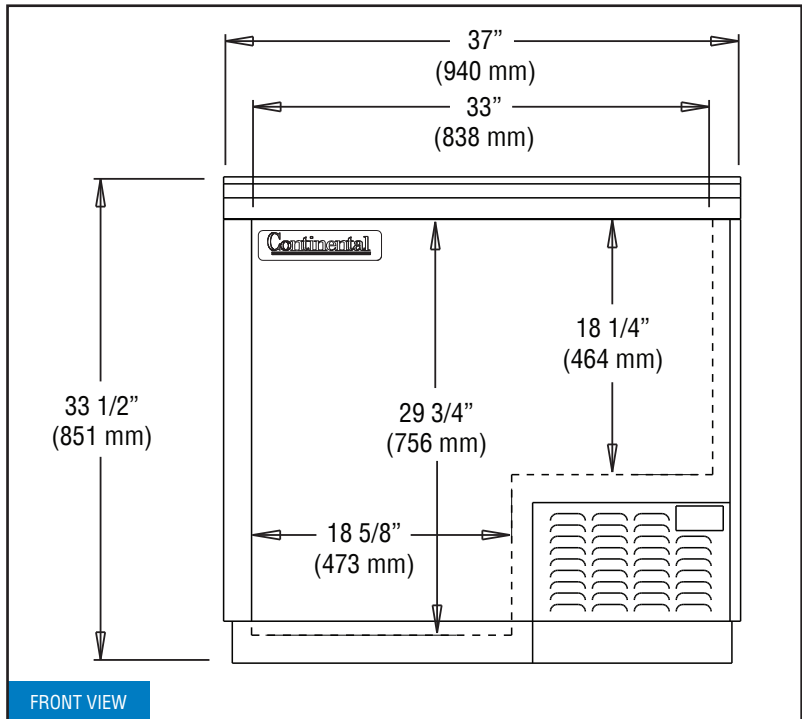

IMPORTANT NOTE: A minimum clearance of 3" is required on each side, front and rear of cabinet for optimum performance.

Continental[®]

Refrigerator

Toll-Free: 800-523-7138
Phone: 215-244-1400
Fax: 215-244-9579

539 Dunkserry Road
Bensalem, PA 19020
www.continentalrefrigerator.com

Due to our continued efforts in developing innovative products, specifications subject to change without notice.



Intertek



MADE IN THE U.S.A.

© Copyright 2016. Continental Refrigerator.
A Division of National Refrigeration & Air Conditioning Products, Inc.