

# DESIGNER LINE FISH FILE

## Model: DLRA68-SS-F

### 68" Fish File Base

Specially designed for the storage of fresh fish packed in crushed ice in drawer pans supplied with unit.

#304 Series stainless steel interior, stainless steel exterior.

**Designed to maintain NSF-7 temperatures in 100°F ambient.**



*Designer Line*

### Options and Accessories

(upcharge and lead times may apply)

Drawer section above the condensing unit*	Condensing unit left or right
Overshelves (single or double)	Door/drawer locks
Automatic, electric condensate evaporator	Casters
Digital thermometer	Front breathing
Stainless steel back	5 1/2" Backsplash

\*Drawer section above condensing unit holds (1) 12 x 20 x 6 pan (not supplied). This section is not set up for fish storage.

Project Name:

Model Specified:

Location:

Item No:

Quantity:

AIA #:

SIS #:

### Standard Model Features

#### REFRIGERATION SYSTEM

Performance-rated refrigeration system

Environmentally-safe R-134a refrigerant

Unique forced air design utilizes fans (approx. every 12") across the entire back of unit for even distribution of cold

Automatic, energy saving, non-electric condensate evaporator

Non-corrosive, plasticized fin evaporator coil

Easily serviceable, slide-out condensing unit

#### CABINET ARCHITECTURE

2" non-CFC polyurethane foam insulation

Spring loaded, self closing door (over condensing unit)

Magnetic snap-in door/drawer gaskets

Easy glide drawers on heavy-duty drawer track

Fully welded, non-corrosive stainless steel pan per drawer with built-in drain tubes and ice grates (drain into gutter)

Refrigerated door section above the condensing unit\*

Adjustable 6" stainless steel legs

#### MODEL FEATURES

External dial thermometer

1" diameter floor cleanout drain

Expansion valve for quick recovery

Built-in, off-cycle defrost timer

**NOTE:** DLRA-F models come standard with a door over the condensing unit. A drawer over the condensing unit is an option. **This section is not set up for fish storage.**

**Continental**<sup>®</sup>  
Refrigerator

Toll-Free: 800-523-7138  
Phone: 215-244-1400  
Fax: 215-244-9579

539 Dunksferry Road  
Bensalem, PA 19020  
[www.continentalrefrigerator.com](http://www.continentalrefrigerator.com)

APPROVAL:

## Model Specifications

### DIMENSIONAL DATA

Net Capacity (cu. ft.)	22 (623 cu l)
Width, Overall (in.)	68 (1727 mm)
Depth, Overall (in.) (incl. handles & bumpers)	36 1/16 (916 mm)
Height, Overall (in.) (incl. 6" legs)	36 (914 mm)
No. of Drawers	4
No. of Half Doors	1
Interior Depth (in.) (above condenser)	30 (762 mm)
Interior Height (in.) (above condenser)	12 1/2 (318 mm)
Interior Width (in.) (above condenser)	17 (432 mm)

### REFRIGERANT DATA

Condensing Unit Size (H.P.)	1/2
Capacity (BTU/Hr)*	4220

### ELECTRICAL DATA

Voltage (int'l)	115/60/1 (220/50/1)
Fans	4
Total Amps (int'l)	13.0 (8.4)
10 ft. Cord/Plug [attached] (int'l)	Yes (No)

### SHIPPING DATA

Weight (lbs.)	495 (225 kg)
Height - Crated (in.)	43 3/4 (1111 mm)
Width - Crated (in.)	70 (1778 mm)
Depth - Crated (in.)	47 (1194 mm)

### DRAWER PAN CONFIGURATIONS

(1) 20 5/32 x 17 3/4 x 6 pan per drawer  
(can accommodate 12 x 20 perforated pans)

\* Rating @ +25°F evaporator, 90°F ambient

Figures in parentheses reflect metric equivalents rounded to the nearest whole unit.



Equipped with one NEMA-5-15P Plug  
(varies by country)

**Continental**  
Refrigerator

Toll-Free: 800-523-7138  
Phone: 215-244-1400  
Fax: 215-244-9579

539 Dunksferry Road  
Bensalem, PA 19020  
[www.continentalrefrigerator.com](http://www.continentalrefrigerator.com)

Due to our continued efforts in developing innovative products, specifications subject to change without notice.



MADE IN THE U.S.A.

© Copyright 2016. Continental Refrigerator.  
A Division of National Refrigeration & Air Conditioning Products, Inc.

## Model Plan Views

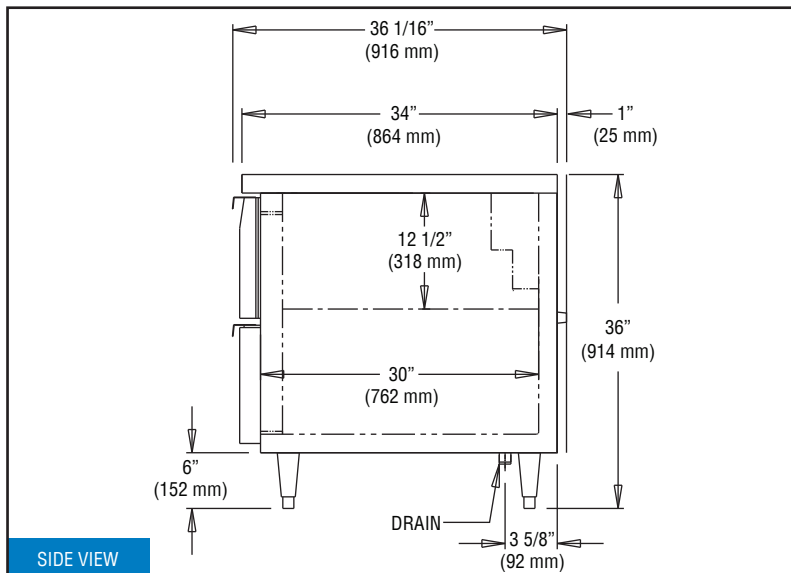
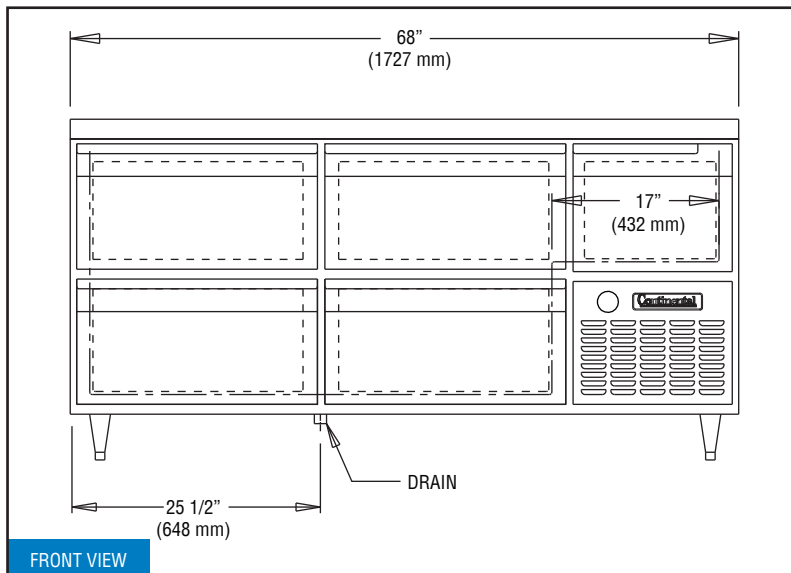

### REFRIGERATION SYSTEM

Self-contained refrigeration system is rear mounted, concealed behind a removable louvered cover. A "performance rated", air-cooled, hermetically sealed, capillary type refrigeration system is installed in model. Plasticized finned coil and air circulating fans are contained within an easily accessible rear mounted housing. Unique airflow design allows the cabinet to be enclosed on both sides or mounted flush against a wall. Refrigeration system, fully charged with R-134a refrigerant, is designed to maintain 38°-41°F while operating with an unrestricted air supply in an ambient temperature of 100°F. All evaporator condensate water is directed to a non-electric condensate evaporator located in the compressor compartment, no plumbing is required. A strict quality assurance team inspects all materials and components to certify the model conforms to the most exacting standards. Model is performance tested for a minimum of 16 hours prior to crating.

### INSULATION

All cabinet walls, top and bottom have high density, foamed-in-place, non-CFC polyurethane insulation.

### CABINET CONSTRUCTION

Materials are top quality, assembled under rigid supervision conforming to strict quality assurance requirements. Case is welded metal construction, internally supported and braced for rigid unit construction. Exterior, interior and worktop are heavy gauge polished stainless steel. Design eliminates overlapping panels with raw edges. Interior corners are rounded with 1/4" radius. Joints and seams are vapor-tight sealed. Easily removable anti-sweat door heaters, concealed by non-metallic, non-conductive, high impact thermal breaker strips, eliminates condensation build-up on case front.

### DRAWER CONSTRUCTION

Drawers are constructed of heavy-gauge, polished stainless steel. Drawer fronts are insulated with non-CFC polyurethane foam insulation. Full extension, lift-out drawer frames are heavy gauge, welded stainless steel mounted on heavy-duty, easy glide, self closing drawer slides. Self adjusting, full perimeter, magnetic snap-in gaskets guarantee a positive seal. **Condensation from pans and water from ice is drained by drawer gutters to the floor of the cabinet where a 1" male pipe connection must drain to a floor sink nearby.**