

UNDERCOUNTER REFRIGERATOR

Model: SW27-U

27" Undercounter Refrigerator with Solid Door

Stainless steel front, top and end panels, aluminum back and interior.

Designed to maintain NSF-7 temperatures in 100°F ambient.



Options and Accessories

(upcharge and lead times may apply)

| | |
|---------------------------------------|--|
| Stainless steel interior | Automatic electric condensate evaporator |
| Stainless steel back | Expansion valve system |
| Stainless steel shelves | Door lock |
| Additional epoxy-coated steel shelves | Special electrical requirements (consult factory) |
| Drawers in lieu of door | |

Consult factory for other model configurations, options and accessories.

Continental
Refrigerator

Toll-Free: 800-523-7138
Phone: 215-244-1400
Fax: 215-244-9579

539 Dunksferry Road
Bensalem, PA 19020
www.continentalrefrigerator.com

Project Name:

Model Specified:

Location:

Item No:

Quantity:

AIA #:

SIS #:

Standard Model Features

REFRIGERATION SYSTEM

- Performance-rated refrigeration system
- Environmentally-safe R-134a refrigerant
- Automatic, energy-saving, non-electric condensate evaporator
- Non-corrosive, plasticized fin evaporator coil
- Easily serviceable back mounted compressor

CABINET ARCHITECTURE

- 2" non-CFC polyurethane foam insulation
- Spring loaded, self closing door
- Magnetic snap-in door gasket
- Heavy-duty, epoxy-coated steel shelf
- Completely enclosed, vented and removable case back
- 1 3/8" diameter plate casters (factory installed)

MODEL FEATURES

- Electronic controller w/ digital display
- 2" high, bottom mounted front breather air divider
- Field rehingeable door

APPROVAL:

Model Specifications

DIMENSIONAL DATA

| | |
|---|-------------------|
| Net Capacity (cu. ft.) | 7.4 (210 cu l) |
| Width, Overall (in.) | 27 1/2 (699 mm) |
| Depth, Overall (in.) (incl. handle & bumpers) | 31 9/16 (802 mm) |
| Height, Overall (in.) (incl. 1 3/8" plate casters) | 31 13/16 (808 mm) |
| Shelf Area (sq. ft.) | 3.5 (.3 sq m) |
| No. of Shelves | 1 |
| No. of Doors | 1 |
| Interior Depth (in.) | See Drawing |
| Interior Height (in.) | 26 1/4 (667 mm) |
| Interior Width (in.) | 24 1/2 (622 mm) |

REFRIGERANT DATA

| | |
|-----------------------------|------|
| Condensing Unit Size (H.P.) | 1/5 |
| Capacity (BTU/Hr)* | 1620 |

ELECTRICAL DATA

| | |
|-------------------------------------|---------------------|
| Voltage (int'l) | 115/60/1 (220/50/1) |
| Fans | 1 |
| Total Amps (int'l) | 6.3 (3.7) |
| 10 ft. Cord/Plug [attached] (int'l) | Yes (No) |

SHIPPING DATA

| | |
|-----------------------|------------------|
| Weight (lbs.) | 165 (75 kg) |
| Height - Crated (in.) | 43 1/4 (1099 mm) |
| Width - Crated (in.) | 35 3/4 (908 mm) |
| Depth - Crated (in.) | 37 1/4 (946 mm) |

* Rating @ +25°F evaporator, 90°F ambient

Figures in parentheses reflect metric equivalents rounded to the nearest whole unit.



Equipped with one NEMA-5-15P Plug
(varies by country)

Model Plan Views

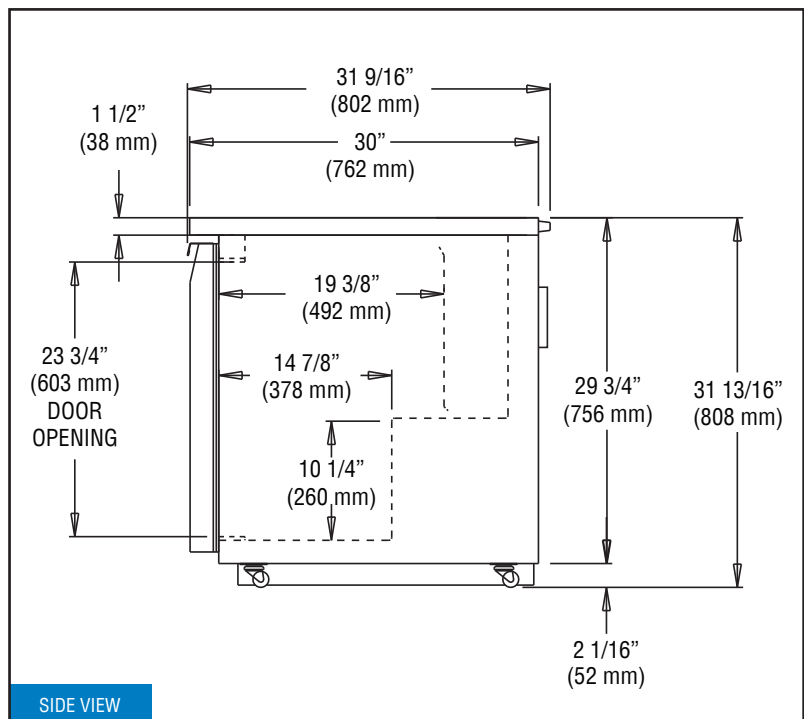
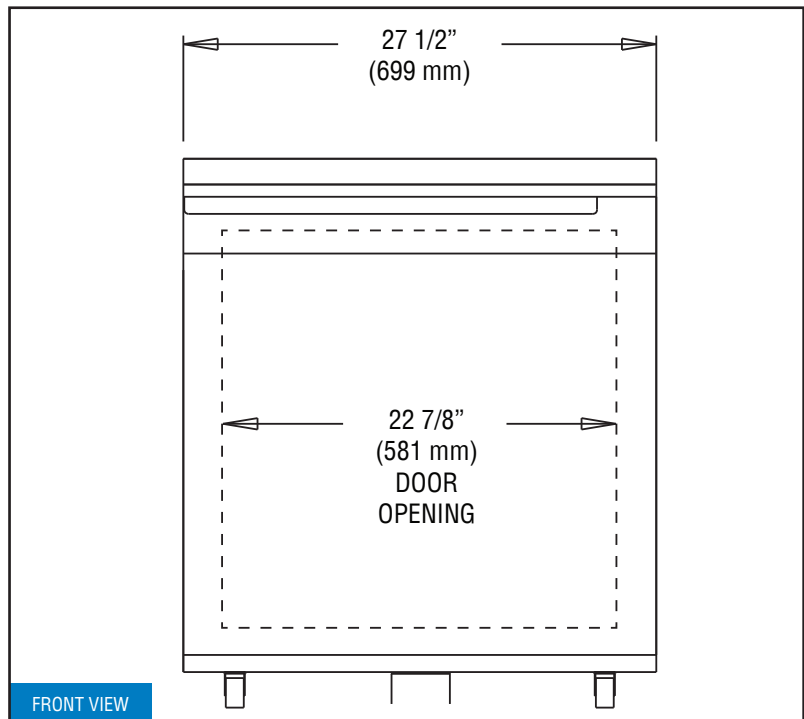

NOTE: For proper operation, the area under and in front of the cabinet **must** not be obstructed in any way.

Continental
Refrigerator

Toll-Free: 800-523-7138
Phone: 215-244-1400
Fax: 215-244-9579

539 Dunkserry Road
Bensalem, PA 19020
www.continentalrefrigerator.com

Due to our continued efforts in developing innovative products, specifications subject to change without notice.



MADE IN THE U.S.A.

© Copyright 2017. Continental Refrigerator.
A Division of National Refrigeration & Air Conditioning Products, Inc.