

UNDERCOUNTER REFRIGERATOR

Model: SW32-U-D

32" Undercounter Refrigerator with Drawers

Stainless steel front, top and end panels, aluminum back and interior.

Designed to maintain NSF-7 temperatures in 100°F ambient.



Options and Accessories

(upcharge and lead times may apply)

Stainless steel interior	Expansion valve system
Stainless steel back	Drawer locks
Solid door in lieu of drawers	Special electrical requirements (consult factory)
Automatic electric condensate evaporator	

Consult factory for other model configurations, options and accessories.

Continental
Refrigerator

Toll-Free: 800-523-7138
Phone: 215-244-1400
Fax: 215-244-9579

539 Dunksferry Road
Bensalem, PA 19020
www.continentalrefrigerator.com

Project Name:

Model Specified:

Location:

Item No:

Quantity:

AIA #:

SIS #:

Standard Model Features

REFRIGERATION SYSTEM

Performance-rated refrigeration system

Environmentally-safe R-134a refrigerant

Automatic, energy-saving, non-electric condensate evaporator

Non-corrosive, plasticized fin evaporator coil

Easily serviceable back mounted compressor

CABINET ARCHITECTURE

2" non-CFC polyurethane foam insulation

Stainless steel roll-out drawers

Magnetic snap-in drawer gaskets

Completely enclosed, vented and removable case back

1 3/8" diameter plate casters (factory installed)

MODEL FEATURES

Electronic controller w/ digital display

2" high, bottom mounted front breather air divider

APPROVAL:

Model Specifications

DIMENSIONAL DATA

Net Capacity (cu. ft.)	9.0 (255 cu l)
Width, Overall (in.)	32 (813 mm)
Depth, Overall (in.) (incl. handles & bumpers)	31 9/16 (802 mm)
Height, Overall (in.) (incl. 1 3/8" plate casters)	31 13/16 (808 mm)
No. of Drawers (two tier)	2
No. of Drawers (three tier)	3

REFRIGERANT DATA

Condensing Unit Size (H.P.)	1/5
Capacity (BTU/Hr)*	1620

ELECTRICAL DATA

Voltage (int'l)	115/60/1 (220/50/1)
Fans	2
Total Amps (int'l)	6.3 (3.7)
10 ft. Cord/Plug [attached] (int'l)	Yes (No)

SHIPPING DATA

Weight (lbs.)	221 (100 kg)
Height - Crated (in.)	43 1/4 (1099 mm)
Width - Crated (in.)	39 (991 mm)
Depth - Crated (in.)	37 1/4 (946 mm)

DRAWER PAN CONFIGURATIONS

Two Tier: (1) 12 x 20 x 6 pan per drawer
or (1) 1/2 size x 6 & (1) 1/3 size x 6 pan per drawer

Three Tier: (1) 12 x 20 x 4 pan per drawer
or (1) 1/2 size x 4 & (2) 1/3 size x 4 pans per drawer

* Rating @ +25°F evaporator, 90°F ambient

Figures in parentheses reflect metric equivalents rounded to the nearest whole unit.



Equipped with one NEMA-5-15P Plug
(varies by country)

Model Plan Views

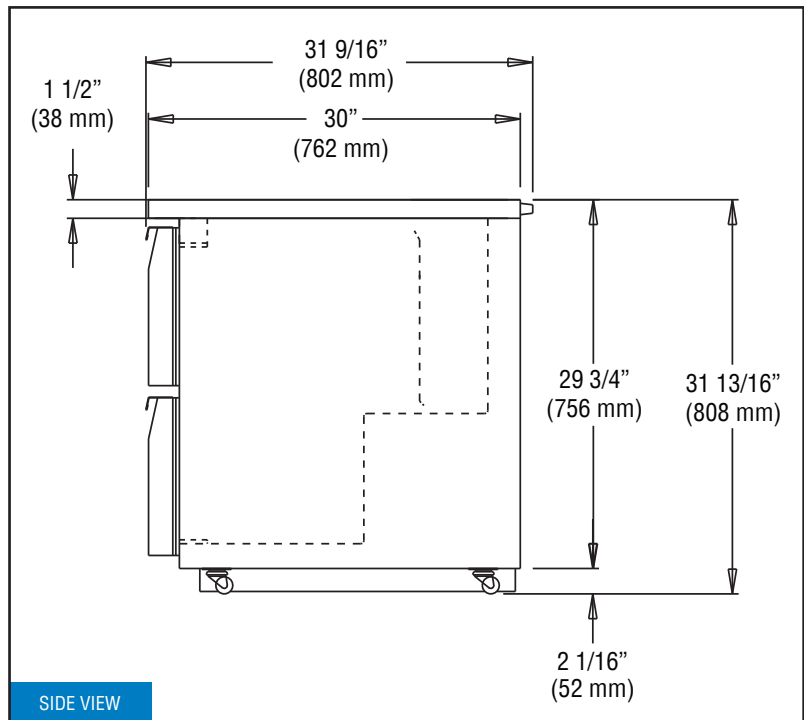
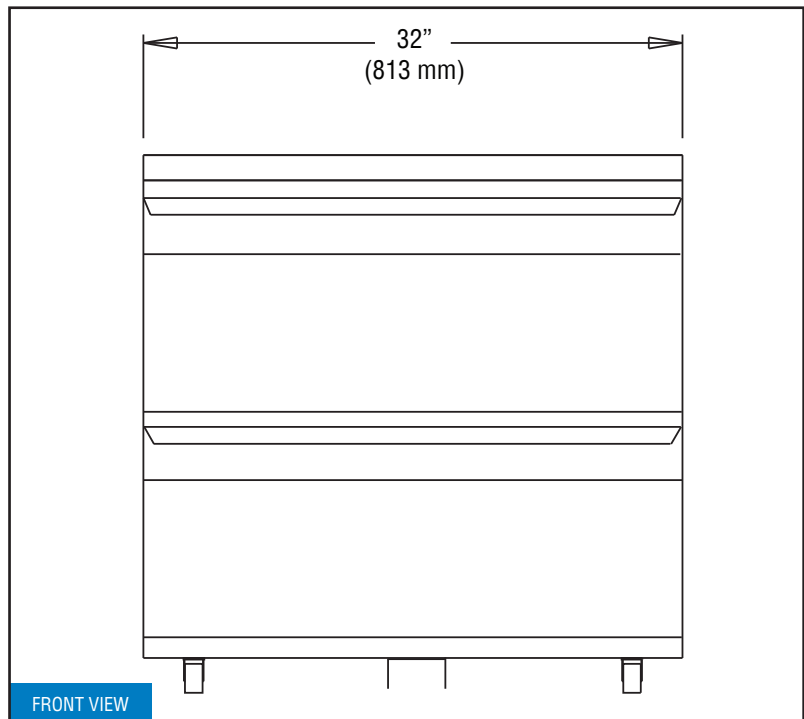

NOTE: For proper operation, the area under and in front of the cabinet **must** not be obstructed in any way.

Continental
Refrigerator

Toll-Free: 800-523-7138
Phone: 215-244-1400
Fax: 215-244-9579

539 Dunkserry Road
Bensalem, PA 19020
www.continentalrefrigerator.com

Due to our continued efforts in developing innovative products, specifications subject to change without notice.



MADE IN THE U.S.A.

© Copyright 2017. Continental Refrigerator.
A Division of National Refrigeration & Air Conditioning Products, Inc.