

# UNDERCOUNTER REFRIGERATOR

**Model: SW72-U-D**

## 72" Undercounter Refrigerator with Drawers

Stainless steel front, top and end panels, aluminum back and interior.

Designed to maintain NSF-7 temperatures in 100°F ambient.



### Options and Accessories

(upcharge and lead times may apply)

Stainless steel interior	Expansion valve system
Stainless steel back	Drawer locks
Solid doors in lieu of drawers	Special electrical requirements (consult factory)
Automatic electric condensate evaporator	

Consult factory for other model configurations, options and accessories.

**Continental**<sup>®</sup>  
Refrigerator

Toll-Free: 800-523-7138  
Phone: 215-244-1400  
Fax: 215-244-9579

539 Dunksferry Road  
Bensalem, PA 19020  
[www.continentalrefrigerator.com](http://www.continentalrefrigerator.com)

Project Name:

Model Specified:

Location:

Item No:

Quantity:

AIA #:

SIS #:

### Standard Model Features

#### REFRIGERATION SYSTEM

Performance-rated refrigeration system

Environmentally-safe R-134a refrigerant

Automatic, energy-saving, non-electric condensate evaporator

Non-corrosive, plasticized fin evaporator coil

Easily serviceable back mounted compressor

#### CABINET ARCHITECTURE

2" non-CFC polyurethane foam insulation

Stainless steel roll-out drawers

Magnetic snap-in drawer gaskets

Completely enclosed, vented and removable case back

1 3/8" diameter plate casters (factory installed)

#### MODEL FEATURES

Electronic controller w/ digital display

2" high, bottom mounted front breather air divider

APPROVAL:

## Model Specifications

### DIMENSIONAL DATA

Net Capacity (cu. ft.)	20.6 (583 cu l)
Width, Overall (in.)	72 (1829 mm)
Depth, Overall (in.) (incl. handles & bumpers)	31 9/16 (802 mm)
Height, Overall (in.) (incl. 1 3/8" plate casters)	31 13/16 (808 mm)
No. of Drawers (two tier)	6
No. of Drawers (three tier)	9

### REFRIGERANT DATA

Condensing Unit Size (H.P.)	1/4
Capacity (BTU/Hr)*	1940

### ELECTRICAL DATA

Voltage (int'l)	115/60/1 (220/50/1)
Fans	4
Total Amps (int'l)	7.6 (4.7)
10 ft. Cord/Plug [attached] (int'l)	Yes (No)

### SHIPPING DATA

Weight (lbs.)	318 (144 kg)
Height - Crated (in.)	43 1/4 (1099 mm)
Width - Crated (in.)	80 1/4 (2038 mm)
Depth - Crated (in.)	37 1/4 (946 mm)

### DRAWER PAN CONFIGURATIONS

**Two Tier:** (1) 12 x 18 x 6 pan per drawer  
or (1) 1/2 size x 6 & (1) 1/3 size x 6 pan per drawer

**Three Tier:** (1) 12 x 18 x 3 1/2 pan per drawer  
or (1) 1/2 size x 4 & (2) 1/3 size x 4 pans per drawer

\* Rating @ +25°F evaporator, 90°F ambient

Figures in parentheses reflect metric equivalents rounded to the nearest whole unit.



Equipped with one NEMA-5-15P Plug  
(varies by country)

**Continental**  
Refrigerator

Toll-Free: 800-523-7138  
Phone: 215-244-1400  
Fax: 215-244-9579

539 Dunkserry Road  
Bensalem, PA 19020  
[www.continentalrefrigerator.com](http://www.continentalrefrigerator.com)

Due to our continued efforts in developing innovative products, specifications subject to change without notice.



MADE IN THE U.S.A.

© Copyright 2017. Continental Refrigerator.  
A Division of National Refrigeration & Air Conditioning Products, Inc.

## Model Plan Views

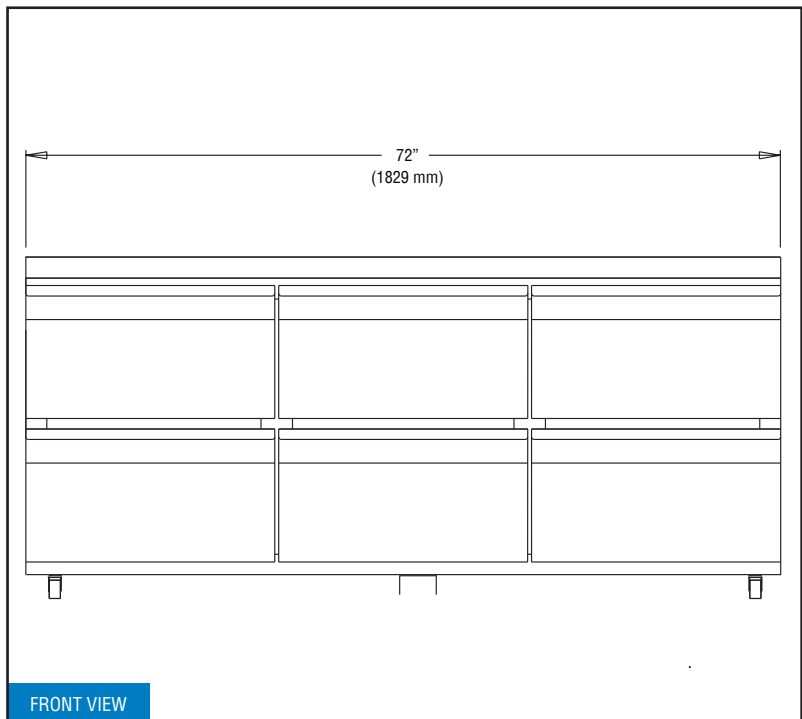

FRONT VIEW

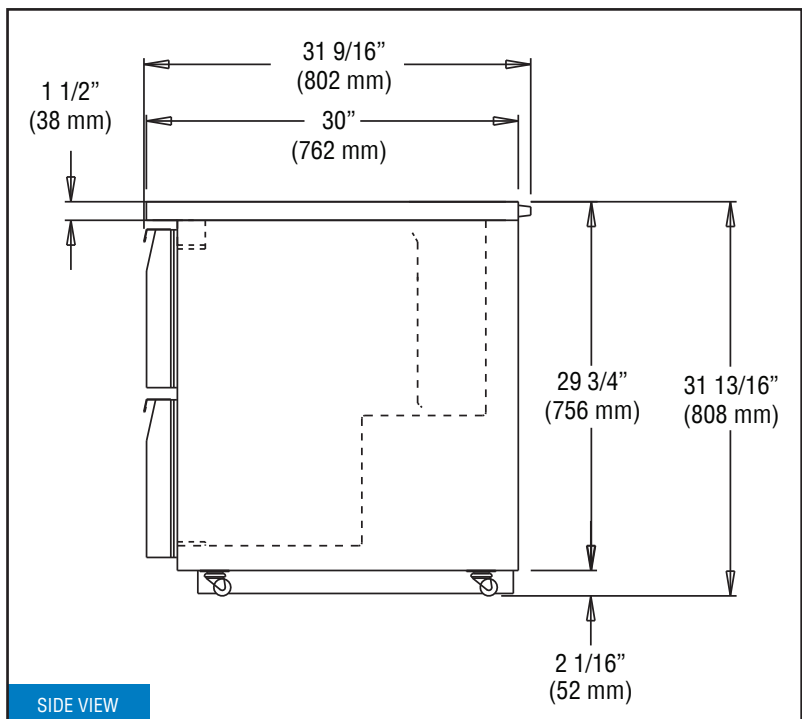

SIDE VIEW

**NOTE:** For proper operation, the area under and in front of the cabinet **must** not be obstructed in any way.