

LOW TEMP FREEZER (-15°F)

Model: 2FE-LT

2-Section Extra-Wide Reach-In Low Temp Freezer

2FE-LT- Stainless steel front, aluminum end panels and interior
 2FE-LT-SA - Stainless steel exterior, aluminum interior
 2FE-LT-SS - Stainless steel exterior and interior
Designed to maintain NSF-7 temperatures in 100°F ambient.



Options and Accessories

(upcharge and lead times may apply)

Stainless steel case back	Pass-Thru (consult factory)
Additional epoxy-coated steel shelves	Shallow depth (consult factory)
Chrome or stainless steel shelves	Hinged glass doors
Heavy-duty pilaster strips	Increased refrigeration systems
Rehinging of doors (consult factory)	Special electrical req. (consult factory)
Pan slide assemblies	Correctional Facility Options
Adjustable legs	• One way security screws
Digital thermometer	• Locking hasp (lock not included)
Custom laminates	• Stainless steel mesh cover
Half doors	• Coverless hinges

Consult factory for other model configurations, options and accessories.

Continental[®]
Refrigerator

Toll-Free: 800-523-7138
 Phone: 215-244-1400
 Fax: 215-244-9579

539 Dunksferry Road
 Bensalem, PA 19020
www.continentalrefrigerator.com

Project Name:

Model Specified:

Location:

Item No:

Quantity:

AIA #:

SIS #:

Standard Model Features

REFRIGERATION SYSTEM

Environmentally-safe R-404A refrigerant

Self contained, performance-rated refrigeration system

Automatic, electric condensate evaporator

CABINET ARCHITECTURE

3" non-CFC polyurethane foam insulation

Smooth, polished chrome workflow door handles

Cam action, lift off hinges

Self-closing doors

Magnetic snap-in door gaskets

Cylinder lock in door

Heavy-duty, epoxy-coated steel shelves

5" casters

MODEL FEATURES

Thermal expansion valve

LED interior lighting

External dial thermometer

Energy saving switch for door heaters

Automatic electric defrost

APPROVAL:

Model Specifications

DIMENSIONAL DATA

Net Capacity (cu. ft.)	50 (1416 cu l)
Width, Overall (in.)	57 (1448 mm)
Depth, Overall (in.) (incl. handles)	35 3/8 (899 mm)
Depth [less doors] (in.)	32 (813 mm)
Depth [doors open 90°] (in.)	58 (1473 mm)
Clear Door Width (in.)	21 7/8 (556 mm)
Clear Door Height (in.)	58 5/8 (1489 mm)
Height, Overall (in.) (incl. 5" casters)	85 3/4 (2178 mm)
No. of Doors	2
No. of Shelves	6
Shelf Area (sq. ft.)	40.8 (3.8 sq m)
Tray Slide Capacity (per section)	24

REFRIGERANT DATA

Condensing Unit Size (H.P.)	1
Capacity (BTU/Hr)*	3600

ELECTRICAL DATA

Voltage (int'l)	115/208-230/60/1 (220/50/1)
Feed Wires (incl. ground)	4
Total Amps (int'l)	13.1 (10.6)
Defrost Amps (int'l)	9.6 (4.8)
10 ft. Cord/Plug (int'l)	No (No)

SHIPPING DATA

Height - Crated (in.)	85 1/2 (2172 mm)
Width - Crated (in.)	64 (1626 mm)
Depth - Crated (in.)	42 (1067 mm)
Volume - Crated (cu. ft.)	133 (3766 cu l)
Weight Std - Crated (lbs.)	565 (256 kg)
Weight SS - Crated (lbs.)	675 (306 kg)
Weight Std - Uncrated (lbs.)	425 (193 kg)
Weight SS - Uncrated (lbs.)	525 (238 kg)

* Rating @ -30°F evaporator, 90°F ambient

Figures in parentheses reflect metric equivalents rounded to the nearest whole unit.

Model Plan Views

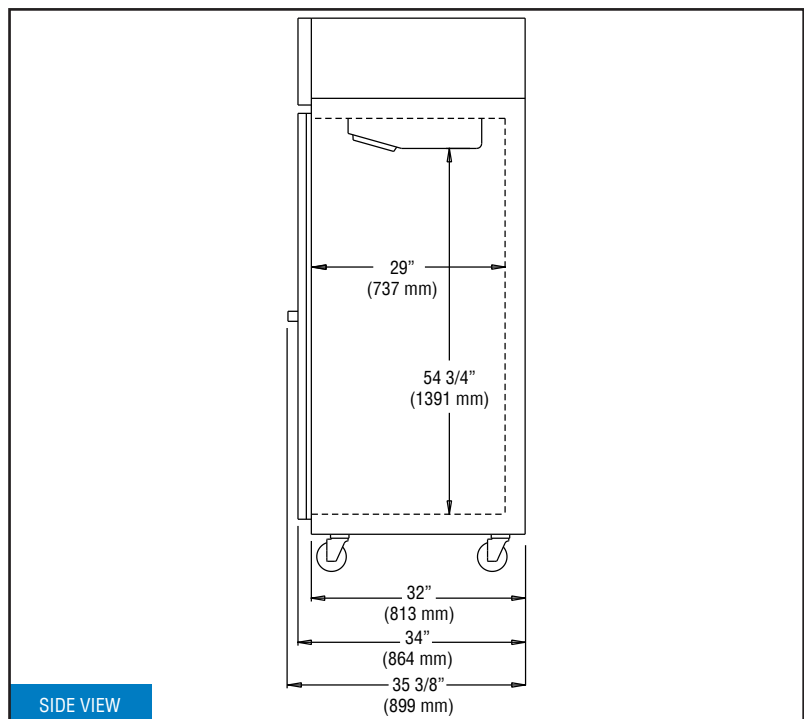
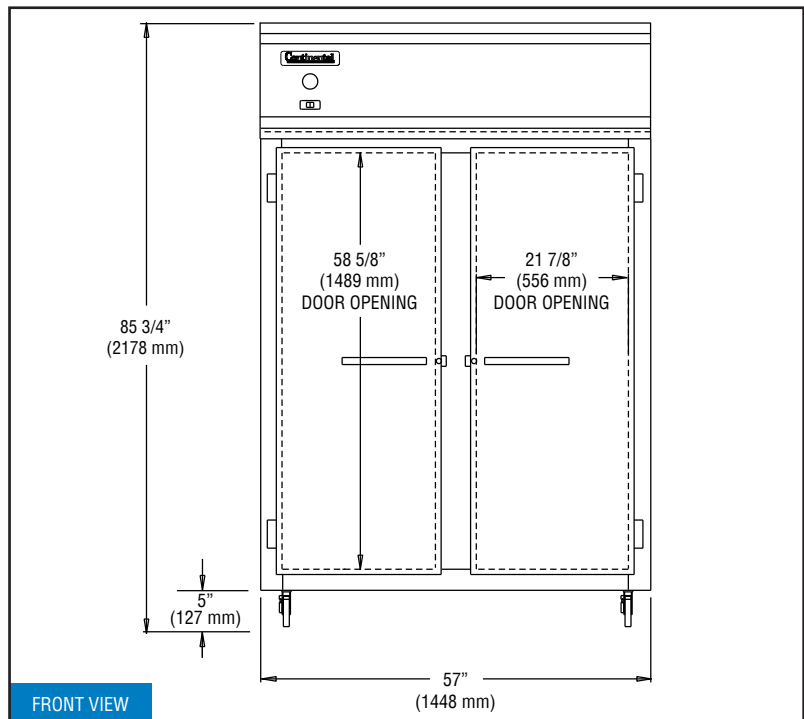

IMPORTANT NOTE: If the cabinet is located directly against a wall and/or under a low ceiling, a minimum clearance of 12" is required on top and 3" on sides and rear.

Continental
Refrigerator

Toll-Free: 800-523-7138
Phone: 215-244-1400
Fax: 215-244-9579

539 Dunkserry Road
Bensalem, PA 19020
www.continentalrefrigerator.com

Due to our continued efforts in developing innovative products, specifications subject to change without notice.



MADE IN THE U.S.A.

© Copyright 2016. Continental Refrigerator.
A Division of National Refrigeration & Air Conditioning Products, Inc.