

# DUAL TEMP REFRIGERATOR/FREEZER

## Model: 2RF

### 2-Section Dual Temp Side-By-Side Reach-In Refrigerator/Freezer (0°F)

2RF - Stainless steel front, aluminum end panels and interior  
 2RF-SA - Stainless steel exterior, aluminum interior  
 2RF-SS - Stainless steel exterior and interior  
**Designed to maintain NSF-7 temperatures in 100°F ambient.**



#### Options and Accessories

(upcharge and lead times may apply)

Stainless steel case back	Pass-Thru (consult factory)
Additional epoxy-coated steel shelves	Shallow depth (consult factory)
Chrome or stainless steel shelves	Hinged glass doors
Heavy-duty pilaster strips	Increased refrigeration systems
Rehinging of doors (consult factory)	Special electrical req. (consult factory)
Expansion valve system	<b>Correctional Facility Options</b>
Adjustable legs	<ul style="list-style-type: none"> <li>One way security screws</li> </ul>
Digital thermometer	<ul style="list-style-type: none"> <li>Locking hasp (lock not included)</li> </ul>
Remote models	<ul style="list-style-type: none"> <li>Stainless steel mesh cover</li> </ul>
Custom laminates	<ul style="list-style-type: none"> <li>Coverless hinges</li> </ul>
Pan slide assemblies	

Consult factory for other model configurations, options and accessories.

**Continental**  
 Refrigerator

Toll-Free: 800-523-7138  
 Phone: 215-244-1400  
 Fax: 215-244-9579

539 Dunksferry Road  
 Bensalem, PA 19020  
[www.continentalrefrigerator.com](http://www.continentalrefrigerator.com)

Project Name:

Model Specified:

Location:

Item No:

Quantity:

AIA #:

SIS #:

#### Standard Model Features

##### REFRIGERATION SYSTEM

Environmentally-safe R-134a refrigerant (refrigerator)

Environmentally-safe R-404A refrigerant (freezer)

Separate, self contained, performance-rated refrigeration systems

Automatic, electric condensate evaporator

##### CABINET ARCHITECTURE

3" non-CFC polyurethane foam insulation

Chrome-plated flow line handles

Cam action, lift off hinges

Self-closing doors

Magnetic snap-in door gaskets

Cylinder lock in door

Heavy-duty, epoxy-coated steel shelves

5" casters

##### MODEL FEATURES

LED interior lighting

External dial thermometer

Energy saving switch for door heaters

Automatic electric defrost (freezer section)

APPROVAL:

## Model Specifications

### DIMENSIONAL DATA

Net Capacity (cu. ft.)	20/20 (566/566 cu l)
Width, Overall (in.)	52 (1321 mm)
Depth, Overall (in.) (incl. handles)	35 3/8 (899 mm)
Depth [less doors] (in.)	32 (813 mm)
Depth [doors open 90°] (in.)	55 1/2 (1410 mm)
Clear Door Width (in.)	19 3/8 (492 mm)
Clear Half Door Height (in.)	58 5/8 (1489 mm)
Height, Overall (in.) (incl. 5" casters)	82 1/4 (2089 mm)
No. of Doors	2
No. of Shelves	6
Shelf Area (sq. ft.) (per section)	20.4 (1.9 sq m)
Tray Slide Capacity (per section)	24 ea.

### REFRIGERANT DATA

Condensing Unit Size (H.P.)	1/4 (R), 1/3 (F)
Capacity (BTU/Hr)*	1940 (R), 1590 (F)

### ELECTRICAL DATA

Voltage (int'l)	115/60/1 (220/50/1)
Feed Wires (incl. ground)	3/3
Total Amps (int'l)	6.9 (3.5), 7.6 (3.8)
Defrost Amps (int'l)	5.2 (2.6)
(2) 10 ft. Cord/Plug [attach.] (int'l)	Yes (No)

### SHIPPING DATA

Height - Crated (in.)	85 1/2 (2172 mm)
Width - Crated (in.)	64 (1626 mm)
Depth - Crated (in.)	42 (1067 mm)
Volume - Crated (cu. ft.)	133 (3766 cu l)
Weight Std - Crated (lbs.)	580 (263 kg)
Weight SS - Crated (lbs.)	700 (318 kg)
Weight Std - Uncrated (lbs.)	410 (186 kg)
Weight SS - Uncrated (lbs.)	530 (240 kg)

\* Rating @ +25°F evaporator, 90°F ambient (refrigerator)

\* Rating @ -15°F evaporator, 90°F ambient (freezer)

Figures in parentheses reflect metric equivalents rounded to the nearest whole unit.

## Model Plan Views

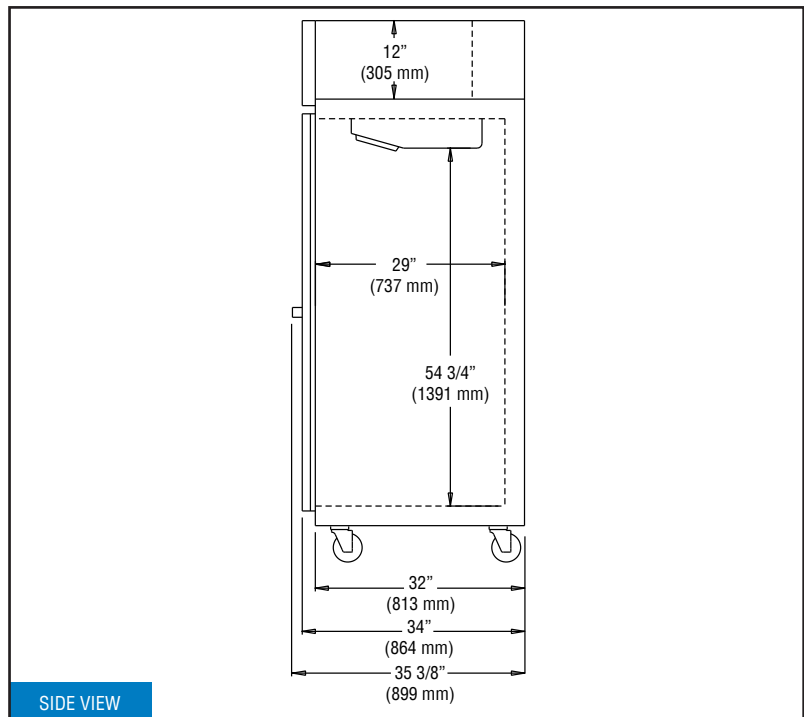
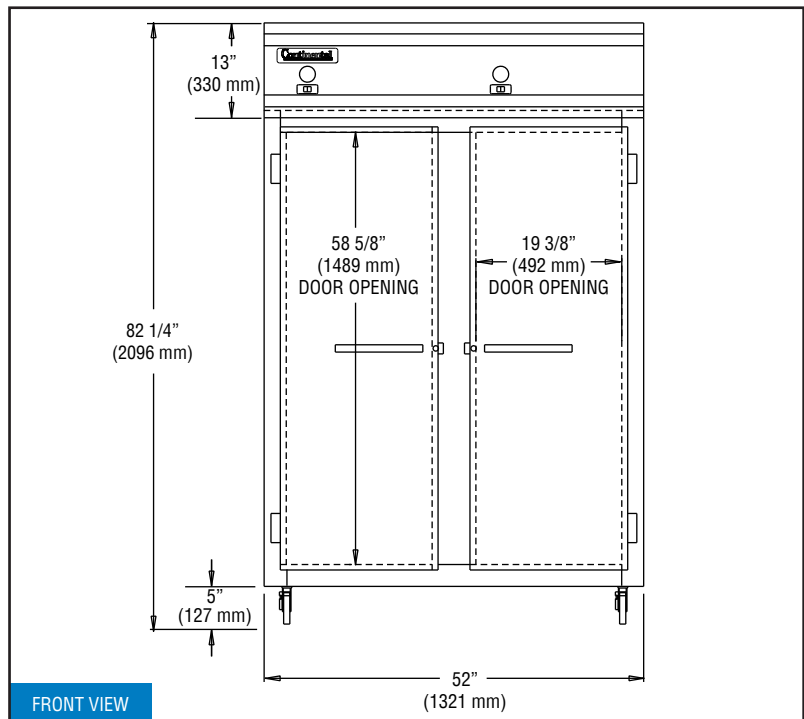

**IMPORTANT NOTE:** If the cabinet is located directly against a wall and/or under a low ceiling, a minimum clearance of 12" is required.

**Continental**  
Refrigerator

Toll-Free: 800-523-7138  
Phone: 215-244-1400  
Fax: 215-244-9579

539 Dunkserry Road  
Bensalem, PA 19020  
[www.continentalrefrigerator.com](http://www.continentalrefrigerator.com)

Due to our continued efforts in developing innovative products, specifications subject to change without notice.



MADE IN THE U.S.A.

© Copyright 2015. Continental Refrigerator.  
A Division of National Refrigeration & Air Conditioning Products, Inc.



Equipped with two NEMA-5-15P Plugs  
(varies by country)