

DESIGNER LINE REFRIGERATOR/WARMER

Model: DL2RW-PT

2-Section Dual Temp, Pass-Thru Refrigerator/Warmer

Refrigerator (left)/Warmer (right). Sections can be changed at time of order.

- DL2RW-PT** - Stainless steel front, aluminum end panels and interior
- DL2RW-SA-PT** - Stainless steel exterior, aluminum interior
- DL2RW-SS-PT** - Stainless steel exterior and interior
- Designed to maintain NSF-7 temperatures in 100°F ambient.**



Options and Accessories

(upcharge and lead times may apply)

Stainless steel case back	Hinged glass doors
Chrome or stainless steel shelves	Increased refrigeration systems
Pan slide assemblies	Special electrical req. (consult factory)
Rehinging of doors (consult factory)	Refrigerator Section Only
Expansion valve system	Additional epoxy-coated steel shelves
Casters	Wine display
Dial thermometer	Correctional Facility Options
Remote models	• One way security screws
Custom laminates	• Locking hasp (lock not included)
Half doors	• Stainless steel mesh cover
Reach-In	• Coverless hinges
Shallow depth	

Consult factory for other model configurations, options and accessories.

Continental
Refrigerator

Toll-Free: 800-523-7138
Phone: 215-244-1400
Fax: 215-244-9579

539 Dunksferry Road
Bensalem, PA 19020
www.continentalrefrigerator.com

Project Name:

Model Specified:

Location:

Item No:

Quantity:

AIA #:

SIS #:

Standard Model Features

REFRIGERATOR SECTION

- Environmentally-safe R-134a refrigerant
- Self-contained, performance-rated "plug" refrigeration system
- Energy saving switch for door heaters
- Heavy-duty, epoxy-coated steel shelves

WARMER SECTION

- Separate, self-contained, performance-rated warming system
- 90°F to 180°F temperature range
- Heavy duty, chrome-plated steel shelves
- Top mounted heating plenum "plug" with circulating fan
- Humidity relief vent
- Exterior temperature control with master on/off switch
- Stainless steel strip heaters located in base of interior

CABINET ARCHITECTURE

- 3" non-CFC polyurethane foam insulation
- Smooth, polished chrome workflow door handles
- Cam action, lift off hinges
- Self-closing doors
- Magnetic snap-in door gaskets
- Cylinder lock in door
- Adjustable 6" stainless steel legs

MODEL FEATURES

- Automatic interior lighting
- External digital thermometers
- Automatic, hot gas condensate evaporator
- Refrigeration/heating system is readily accessible on top of cabinet, separate from the "food zone"
- Top and side air distribution ducts
- Cabinet upper side panels and refrigeration "plug" system can be removed and reinstalled on job site

APPROVAL:

Model Specifications

DIMENSIONAL DATA

Net Capacity (cu. ft.)	21 / 21 (595 / 595 cu l)
Width, Overall (in.)	52 (1321 mm)
Depth, Overall (in.) (incl. handles)	38 3/4 (984 mm)
Depth [less doors] (in.)	32 (813 mm)
Depth [doors open 90°] (in.)	79 (2007 mm)
Clear Door Width (in.)	19 3/8 (492 mm)
Clear Door Height (in.)	58 5/8 (1489 mm)
Height, Overall (in.) (incl. 6" legs)	83 1/4 (2115 mm)
No. of Doors	4
No. of Shelves	6
Shelf Area (sq. ft.) (total area)	40.8 (3.8 sq m)
Tray Slide Capacity (per section)	24

REFRIGERANT DATA

Condensing Unit Size (H.P.)	1/4
Capacity (BTU/Hr)*	1940

ELECTRICAL DATA

Voltage [refrigerator] (int'l)	115/60/1 (220/50/1)
Voltage [warmer]	115-208/230-60-1
Feed Wires (incl. ground)	3 / 4
Total Amps (int'l)	5.5 (3.5) / 7.8 (7.2)
Total Wattage @ 208-230 volts	2250
10 ft. Cord/Plug (int'l)	Yes (No) / No

SHIPPING DATA

Height - Crated (in.)	85 1/2 (2172 mm)
Width - Crated (in.)	64 (1626 mm)
Depth - Crated (in.)	42 (1067 mm)
Volume - Crated (cu. ft.)	133 (3766 cu l)
Weight Std - Crated (lbs.)	595 (270 kg)
Weight SS - Crated (lbs.)	675 (306 kg)
Weight Std - Uncrated (lbs.)	425 (193 kg)
Weight SS - Uncrated (lbs.)	505 (229 kg)

* Rating @ +25°F evaporator, 90°F ambient (refrigerator)
 Figures in parentheses reflect metric equivalents rounded to the nearest whole unit.

Refrigerator Section Only:
 Equipped with one NEMA-5-15P Plug (varies by country)



Continental

Refrigerator

Toll-Free: 800-523-7138
 Phone: 215-244-1400
 Fax: 215-244-9579

539 Dunksferry Road
 Bensalem, PA 19020
www.continentalrefrigerator.com

Due to our continued efforts in developing innovative products, specifications subject to change without notice.



© Copyright 2015, Continental Refrigerator.
 A Division of National Refrigeration & Air Conditioning Products, Inc.

Model Plan Views

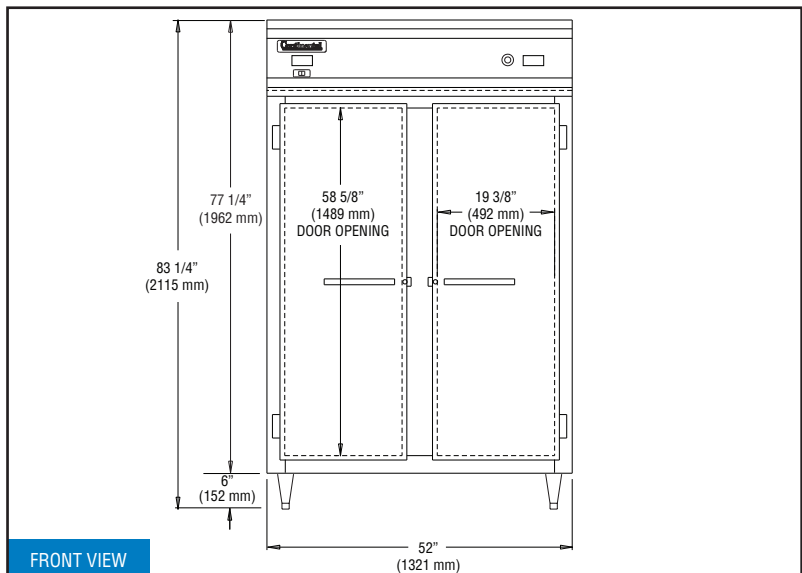

FRONT VIEW

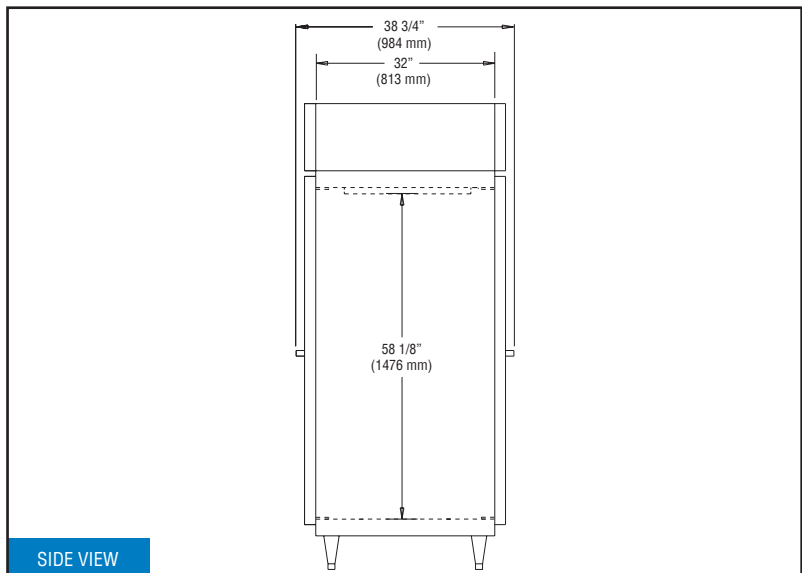

SIDE VIEW

IMPORTANT NOTE: If the cabinet is located directly against a wall and/or under a low ceiling, a minimum clearance of 12" is required.

REFRIGERATION SYSTEM

A "performance rated", air-cooled, hermetically sealed, capillary-type refrigeration system is installed on the top of each refrigerator. Plasticized fin coil and air circulation fans are contained within a concealed "plug"-type insulated housing, readily accessible on top of the cabinet and separate from the food zone to increase food storage capacity. The entire "plug" system is fully charged with environmentally safe R-134a refrigerant and mounted on a sturdy steel, rail-type base which can be easily removed if freezer conversion is desired. Refrigerators are designed to maintain 38°F-40°F (3°-5° Centigrade) while operating with an unrestricted air supply in a maximum ambient temperature of 100°F. All condensate water is evaporated by an automatic, non-electric, corrosion-resistant condensate evaporator. A strict quality-assurance team inspects all materials and components to certify that each model conforms to the most exacting standards. All models are factory performance-tested for a minimum of 16 hours prior to crating.

HEATING SYSTEM (Range 90°F - 180°F)

Electrically operated heating system is controlled by means of a highly sensitive calibrated thermostat mounted on the cabinet front. Fin strip heating elements are located at the base of the interior. Air circulating blower located in a top mounted, concealed "plug" housing distributes heat throughout product zone, assuring uniform cabinet temperatures. Cabinet top has a built-in humidity relief vent. The entire "plug" system is mounted on a sturdy steel, rail-type base which can be easily removed if refrigerator or freezer conversion is desired. A strict quality assurance team inspects all material and components to certify that each model

conforms to the most exacting standards. All models are factory performance tested for a minimum of 16 hours prior to crating.

CABINET CONSTRUCTION

All materials are top quality, assembled to conform with strict quality-assurance requirements. The cabinet front and doors are constructed of heavy-gauge polished stainless steel for durability. All cabinet joints and seams are sealed vapor-tight. Case is of all metal, welded construction and internally supported and braced for a rigid unit construction. Cabinet design eliminated overlapping panels with raw edges. Cabinet body and doors are insulated with non-CFC, foamed-in-place polyurethane foam with an average thickness of 3 inches to ensure increased energy efficiency. Full-length louvered air grille located above the doors allows equal air circulation to the condensing unit. Easily removable, low-wattage, anti-sweat door heaters concealed by a non-metallic, non-conductive, high-impact thermal breaker strip eliminate condensate build-up on the cabinet front. Automatic interior lighting is controlled by door openings. Cabinets are equipped with 6" adjustable stainless steel legs.

DOOR CONSTRUCTION

Door shells are constructed of heavy-gauge stainless steel and internally braced and urethane foam insulated for rigidity. Door corners are welded construction and polished. Replaceable snap-in door gaskets are self adjusting, heavy-duty, magnetic type. Door handles and hinges are chrome-plated and non-corrosive. Doors are provided with built-in cylinder locks which are keyed alike. Hinges are cam-action, lift-off type featuring positive safety stop at 120 degrees.

DL2RW-PT (7/10/15)