

GRIDDLE STAND REFRIGERATOR

Model: DL48G

48" Griddle Stand Refrigerator

Stainless steel exterior and interior.

Designed to maintain NSF-7 temperatures in 100°F ambient.



Options and Accessories

(upcharge and lead times may apply)

Doors in lieu of drawers	Adjustable legs
Flat top in lieu of marine edge	Digital thermometer
16-gauge stainless steel top (flat or marine)	Cylinder locks
Condensing unit left or right	Stainless steel pans
Automatic, electric condensate evaporator	Special electrical requirements (consult factory)
Stainless steel top extensions (flat or marine)	

Consult factory for other model configurations, options and accessories.

Continental[®]
Refrigerator

Toll-Free: 800-523-7138
Phone: 215-244-1400
Fax: 215-244-9579

539 Dunksferry Road
Bensalem, PA 19020
www.continentalrefrigerator.com

Project Name:

Model Specified:

Location:

Item No:

Quantity:

AIA #:

SIS #:

Standard Model Features

REFRIGERATION SYSTEM

- Performance-rated refrigeration system
- Environmentally-safe R-134a refrigerant
- Side-mounted, automatic, energy saving non-electric condensate evaporator
- Non-corrosive, plasticized fin evaporator coil
- Easily serviceable, front slide-out condensing unit

CABINET ARCHITECTURE

- High density, non-CFC polyurethane foamed-in-place insulation
- Easy glide, fully extendable drawers designed to hold 6" deep pans side-by-side
- One-piece, snap-in magnetic drawer gaskets
- Heavy-duty drawer track with built-in drawer safety clips
- Drawers designed to hold 250 lb. capacity
- 4" casters on support plates
- Stainless steel case back
- Reinforced stainless steel work top with drip guard marine edge

MODEL FEATURES

- Capillary dial thermometer
- Front breathing

APPROVAL:

Model Specifications

DIMENSIONAL DATA

Net Capacity (cu. ft.)	9.0 (255 cu l)
Width, Overall (in.)	48 (1219 mm)
Depth, Overall (incl. handles) (in.)	34 3/4 (883 mm)
Height, Overall (in.) (incl. 4" casters)	26 3/8 (670 mm)
No. of Drawers	2

REFRIGERANT DATA

Condensing Unit Size (H.P.)	1/5
Capacity (BTU/Hr)*	1725

ELECTRICAL DATA

Voltage (int'l)	115/60/1 (220/50/1)
Fans	1
Feed Wires (incl. ground)	3
Total Amps (int'l)	5.7 (3.1)
10 ft. Cord/Plug [attached] (int'l)	Yes (No)

SHIPPING DATA

Weight (lbs.)	450 (204 kg)
Height - Crated (in.)	44 (1118 mm)
Width - Crated (in.)	64 (1626 mm)
Depth - Crated (in.)	39 (991 mm)

TOP WEIGHT CAPACITY

Max. Top Weight Capacity (lbs.)	775 (352 kg)
---------------------------------	--------------

* Rating @ +25°F evaporator, 90°F ambient

Figures in parentheses reflect metric equivalents rounded to the nearest whole unit.



Equipped with one NEMA-5-15P Plug
(varies by country)

Continental
Refrigerator

Toll-Free: 800-523-7138
Phone: 215-244-1400
Fax: 215-244-9579

539 Dunkserry Road
Bensalem, PA 19020
www.continentalrefrigerator.com

Due to our continued efforts in developing innovative products, specifications subject to change without notice.



Intertek

© Copyright 2016. Continental Refrigerator.

A Division of National Refrigeration & Air Conditioning Products, Inc.



MADE IN THE U.S.A.

Model Plan Views

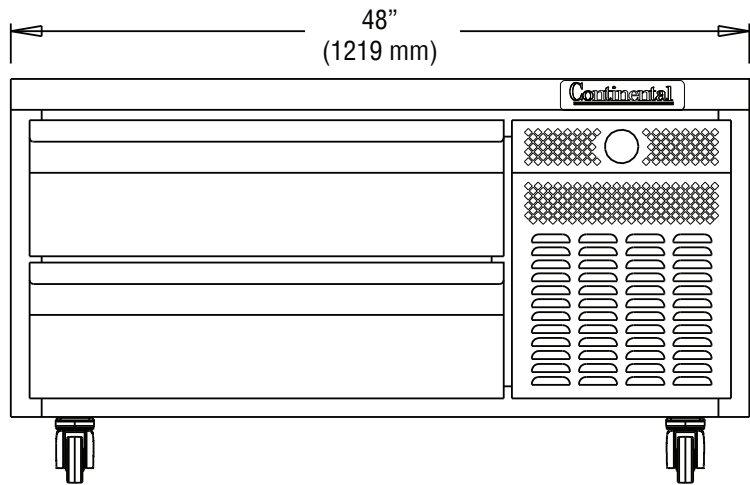

FRONT VIEW

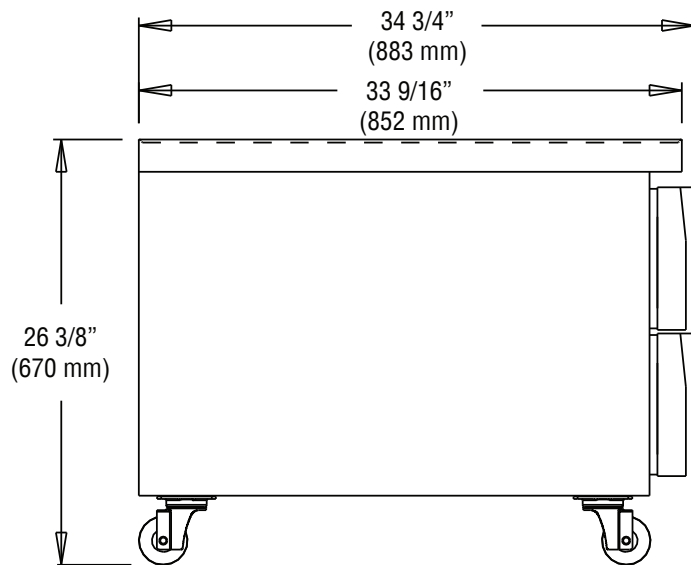

SIDE VIEW

Shown with (4) 12 x 20 x 6 pans (not furnished)

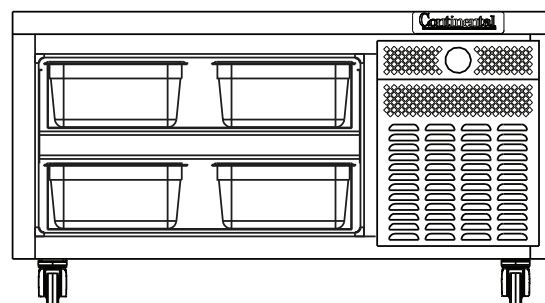

DRAWER PAN CONFIGURATION