

GRIDDLE STAND REFRIGERATOR

Model: DL72G

72" Griddle Stand Refrigerator

Stainless steel exterior and interior.

Designed to maintain NSF-7 temperatures in 100°F ambient.



Options and Accessories

(upcharge and lead times may apply)

Flat top in lieu of marine edge	Adjustable legs
16-gauge stainless steel top (flat or marine)	Digital thermometer
Condensing unit left or right	Cylinder locks
Automatic, electric condensate evaporator	Stainless steel pans
Stainless steel top extensions (flat or marine)	Special electrical requirements (consult factory)

Consult factory for other model configurations, options and accessories.

Continental
Refrigerator

Toll-Free: 800-523-7138
Phone: 215-244-1400
Fax: 215-244-9579

539 Dunksferry Road
Bensalem, PA 19020
www.continentalrefrigerator.com

Project Name:

Model Specified:

Location:

Item No:

Quantity:

AIA #:

SIS #:

Standard Model Features

REFRIGERATION SYSTEM

Performance-rated refrigeration system

Environmentally-safe R-134a refrigerant

Side-mounted, automatic, energy saving non-electric condensate evaporator

Non-corrosive, plasticized fin evaporator coil

Easily serviceable, front slide-out condensing unit

CABINET ARCHITECTURE

High density, non-CFC polyurethane foamed-in-place insulation

Easy glide, fully extendable drawers designed to hold 6" deep pans side-by-side

One-piece, snap-in magnetic drawer gaskets

Heavy-duty drawer track with built-in drawer safety clips

Drawers designed to hold 250 lb. capacity

4" casters on support plates

Stainless steel case back

Reinforced stainless steel work top with drip guard marine edge

MODEL FEATURES

Capillary dial thermometer

Front breathing

APPROVAL:

Model Specifications

DIMENSIONAL DATA

Net Capacity (cu. ft.)	16.4 (464 cu l)
Width, Overall (in.)	72 (1829 mm)
Depth, Overall (incl. handles) (in.)	34 3/4 (883 mm)
Height, Overall (in.) (incl. 4" casters)	26 3/8 (670 mm)
No. of Drawers	4

REFRIGERANT DATA

Condensing Unit Size (H.P.)	1/4
Capacity (BTU/Hr)*	1940

ELECTRICAL DATA

Voltage (int'l)	115/60/1 (220/50/1)
Fans	2
Feed Wires (incl. ground)	3
Total Amps (int'l)	6.1 (3.7)
10 ft. Cord/Plug [attached] (int'l)	Yes (No)

SHIPPING DATA

Weight (lbs.)	550 (249 kg)
Height - Crated (in.)	44 (1118 mm)
Width - Crated (in.)	90 (2286 mm)
Depth - Crated (in.)	39 (991 mm)

TOP WEIGHT CAPACITY

Max. Top Weight Capacity (lbs.)	1200 (544 kg)
---------------------------------	---------------

* Rating @ +25°F evaporator, 90°F ambient

Figures in parentheses reflect metric equivalents rounded to the nearest whole unit.



Equipped with one NEMA-5-15P Plug
(varies by country)

Continental
Refrigerator

Toll-Free: 800-523-7138
Phone: 215-244-1400
Fax: 215-244-9579

539 Dunkserry Road
Bensalem, PA 19020
www.continentalrefrigerator.com

Due to our continued efforts in developing innovative products, specifications subject to change without notice.



Intertek

© Copyright 2016. Continental Refrigerator.

A Division of National Refrigeration & Air Conditioning Products, Inc.



MADE IN THE U.S.A.

Model Plan Views

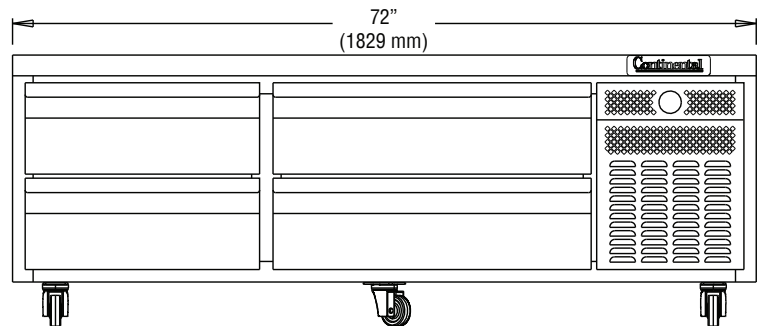

FRONT VIEW

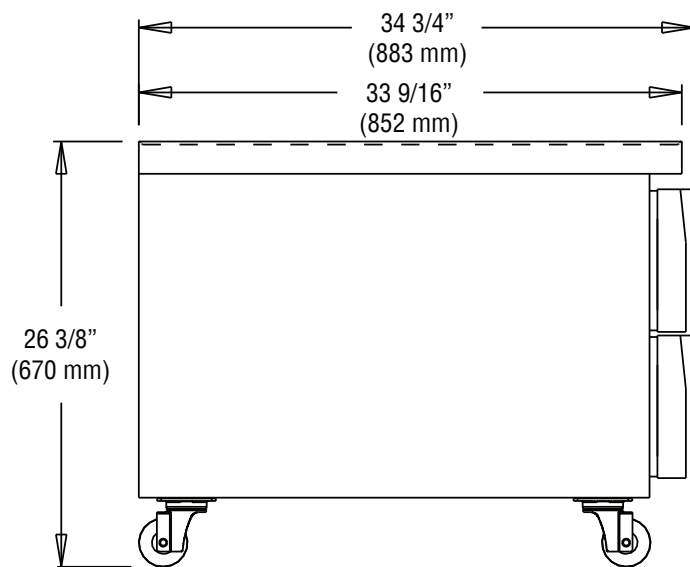

SIDE VIEW

Shown with (6) 12 x 20 x 6 pans and (2) 6 x 20 x 6 pans (not furnished)

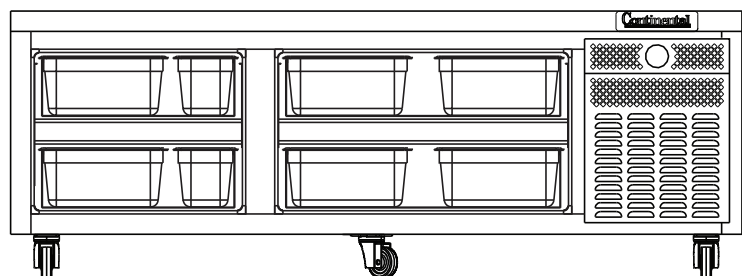

DRAWER PAN CONFIGURATION