

DESIGNER LINE UNDERCOUNTER FREEZER (0°F)

Model: DLF27-SS-U

27" Undercounter Freezer
with Solid Door

Stainless steel exterior and interior with stainless steel top.

Designed to maintain NSF-7 temperatures in 100°F ambient.



Options and Accessories

(upcharge and lead times may apply)

Stainless steel back	Glass door in lieu of solid door
Stainless steel shelves	Door lock
Additional epoxy-coated steel shelves	Special electrical requirements (consult factory)
Drawers in lieu of door	

Consult factory for other model configurations, options and accessories.

Continental[®]
Refrigerator

Toll-Free: 800-523-7138
Phone: 215-244-1400
Fax: 215-244-9579

539 Dunksferry Road
Bensalem, PA 19020
www.continentalrefrigerator.com

Project Name:

Model Specified:

Location:

Item No:

Quantity:

AIA #:

SIS #:

Standard Model Features

REFRIGERATION SYSTEM

Performance-rated refrigeration system
Environmentally-safe R-134a refrigerant
Automatic, hot gas condensate evaporator
Non-corrosive, plasticized fin evaporator coil
Easily serviceable back mounted compressor

CABINET ARCHITECTURE

2" non-CFC polyurethane foam insulation
Spring loaded, self closing door
Magnetic snap-in door gasket
Heavy-duty, epoxy-coated steel shelf
Completely enclosed, vented and removable case back
1 3/8" diameter plate casters (factory installed)

MODEL FEATURES

Electronic controller w/ digital display
2" high, bottom mounted front breather air divider
Automatic electric defrost
Expansion valve system
Field rehingeable door

APPROVAL:

Model Specifications

DIMENSIONAL DATA

Net Capacity (cu. ft.)	7.4 (210 cu l)
Width, Overall (in.)	27 1/2 (699 mm)
Depth, Overall (in.) (incl. handle & bumpers)	31 9/16 (802 mm)
Height, Overall (in.) (incl. 1 3/8" plate casters)	31 13/16 (808 mm)
Shelf Area (sq. ft.)	3.5 (.3 sq m)
No. of Shelves	1
No. of Doors	1
Interior Depth (in.)	See Drawing
Interior Height (in.)	26 1/4 (667 mm)
Interior Width (in.)	24 1/2 (622 mm)

REFRIGERANT DATA

Condensing Unit Size (H.P.)	1/4
Capacity (BTU/Hr)*	1325

ELECTRICAL DATA

Voltage (int'l)	115/60/1 (220/50/1)
Fans	1
Total Amps (int'l)	4.8 (n/a)
Defrost Amps (int'l)	5.7 (n/a)
10 ft. Cord/Plug [attached] (int'l)	Yes (n/a)

SHIPPING DATA

Weight (lbs.)	165 (75 kg)
Height - Crated (in.)	43 1/4 (1099 mm)
Width - Crated (in.)	35 3/4 (908 mm)
Depth - Crated (in.)	37 1/4 (946 mm)

* Rating @ -15°F evaporator, 90°F ambient

Figures in parentheses reflect metric equivalents rounded to the nearest whole unit.



Equipped with one NEMA-5-15P Plug
(varies by country)

Continental[®]

Refrigerator

Toll-Free: 800-523-7138
Phone: 215-244-1400
Fax: 215-244-9579

539 Dunksferry Road
Bensalem, PA 19020
www.continentalrefrigerator.com

Due to our continued efforts in developing innovative products, specifications subject to change without notice.



MADE IN THE U.S.A.

© Copyright 2017. Continental Refrigerator.
A Division of National Refrigeration & Air Conditioning Products, Inc.

Model Plan Views

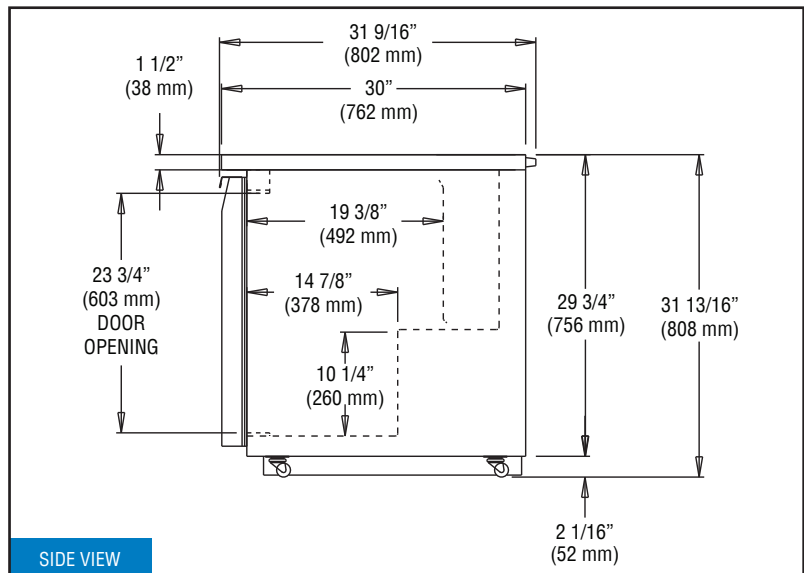
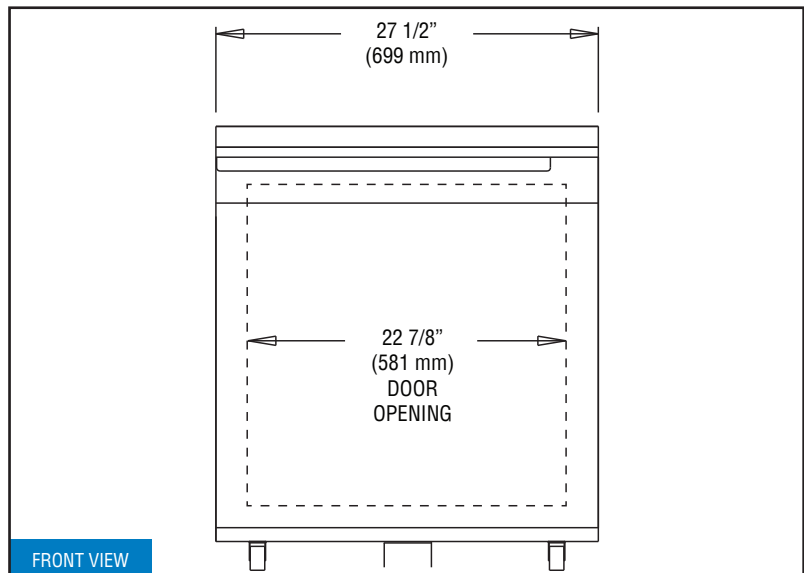

NOTE: For proper operation, the area under and in front of the cabinet **must** not be obstructed in any way.

REFRIGERATION SYSTEM

The self-contained refrigeration system is rear mounted, concealed behind a removable back cover. Bottom mounted, low profile air divider allows for even air circulation to condensing unit. A "performance-rated", air-cooled, hermetically sealed, expansion valve refrigeration system is installed in model. Plasticized finned coil and air circulating fans are contained within an easily accessible rear mounted housing. Unique airflow design allows the cabinet to be enclosed on both sides or mounted flush against a wall. Refrigeration system, fully charged with R-134a refrigerant, is designed to maintain 0°F while operating with an unrestricted air supply in an ambient temperature of 100°F. All condensate water is directed to a hot gas condensate vaporizer located in the compressor compartment, no plumbing is required. A strict quality assurance team inspects all materials and components to certify the model conforms to the most exacting standards. Model is performance tested for a minimum of 16 hours prior to crating.

INSULATION

All cabinet walls, top and bottom have high density, foamed-in-place, non-CFC polyurethane insulation.

CABINET CONSTRUCTION

Materials are top quality, assembled under rigid supervision conforming to strict quality assurance requirements. Case is welded metal construction, internally supported and braced for rigid unit construction. Exterior cabinet back and bottom are heavy-gauge galvanized steel.

Design eliminates overlapping panels with raw edges. Interior corners are rounded with 1/4" radius. Joints and seams are vapor-tight sealed. Easily removable anti-sweat door heaters, concealed by non-metallic, non-conductive, high impact thermal breaker strips, eliminates condensation build-up on case front.

DOOR CONSTRUCTION

Door shells are constructed of heavy-gauge stainless steel and are internally braced with urethane-foam-insulated for rigidity. Door corners are of welded construction and polished. Replaceable snap-in door gaskets are self adjusting, heavy-duty, magnetic type. Door handles and hinges are chrome-plated and non-corrosive. Hinges are spring loaded, heavy duty and self-closing.