

FORCED AIR MILK COOLERS

Model: MC5-S

58" Forced Air Milk Cooler Single Access

White painted steel exterior, stainless steel top and door, heavy-duty stainless steel lid, door hinges and latches, galvanized steel interior with reinforced stainless steel floor. **Designed to keep milk cold during serving.**



Options and Accessories

(upcharge and lead times may apply)

| | |
|--------------------------|---------------------|
| Stainless steel exterior | Adjustable legs |
| Stainless steel interior | Color laminate |
| Wrap around bumpers | Powder coating |
| Corner bumpers | Digital thermometer |
| Foot pedal floor lock | Dual access |

Consult factory for other model configurations, options and accessories.

Project Name:

Model Specified:

Location:

Item No:

Quantity:

AIA #:

SIS #:

Standard Model Features

REFRIGERATION SYSTEM

Forced air, performance-rated refrigeration system
Environmentally-safe R-134a refrigerant
Easily serviceable, bottom-mounted compressor
Built-in, electric condensate evaporator

CABINET ARCHITECTURE

2" high density, non-CFC polyurethane foamed-in-place insulation
Snap-in lid and door gasket
Non-corrosive, heavy-duty, epoxy-coated steel wire floor racks
Door cylinder security lock
5" swivel casters w/ front locking brakes

MODEL FEATURES

Exterior-mounted dial thermometer
Floor drain
Unique forced air flow curtain

Continental
Refrigerator

Toll-Free: 800-523-7138
Phone: 215-244-1400
Fax: 215-244-9579

539 Dunksferry Road
Bensalem, PA 19020
www.continentalrefrigerator.com

APPROVAL:

Model Specifications

DIMENSIONAL DATA

| | |
|--|-----------------|
| Net Capacity (cu. ft.) | 24.0 (680 cu l) |
| Crate Capacity (13" x 13" x 11") | 16 |
| Crate Capacity (19" x 13" x 11") | 10 |
| Width, Overall (in.) | 58 (1473 mm) |
| Depth, Overall (in.) | 33 (838 mm) |
| Height, Overall (in.) (incl. 5" casters) | 47 (1194 mm) |

REFRIGERANT DATA

| | |
|-----------------------------|------|
| Condensing Unit Size (H.P.) | 1/3 |
| Capacity (BTU/Hr)* | 2870 |

ELECTRICAL DATA

| | |
|-------------------------------------|---------------------|
| Voltage (int'l) | 115/60/1 (220/50/1) |
| Total Amps (int'l) | 7.4 (4.3) |
| 10 ft. Cord/Plug [attached] (int'l) | Yes (No) |

SHIPPING DATA

| | |
|-----------------------|------------------|
| Weight (lbs.) | 580 (263 kg) |
| Height - Crated (in.) | 56 1/4 (1429 mm) |
| Width - Crated (in.) | 67 1/4 (1708 mm) |
| Depth - Crated (in.) | 36 1/2 (927 mm) |

* Rating @ +25°F evaporator, 90°F ambient
 Figures in parentheses reflect metric equivalents rounded to the nearest whole unit.



Equipped with one NEMA-5-15P Plug
 (varies by country)

Model Plan Views

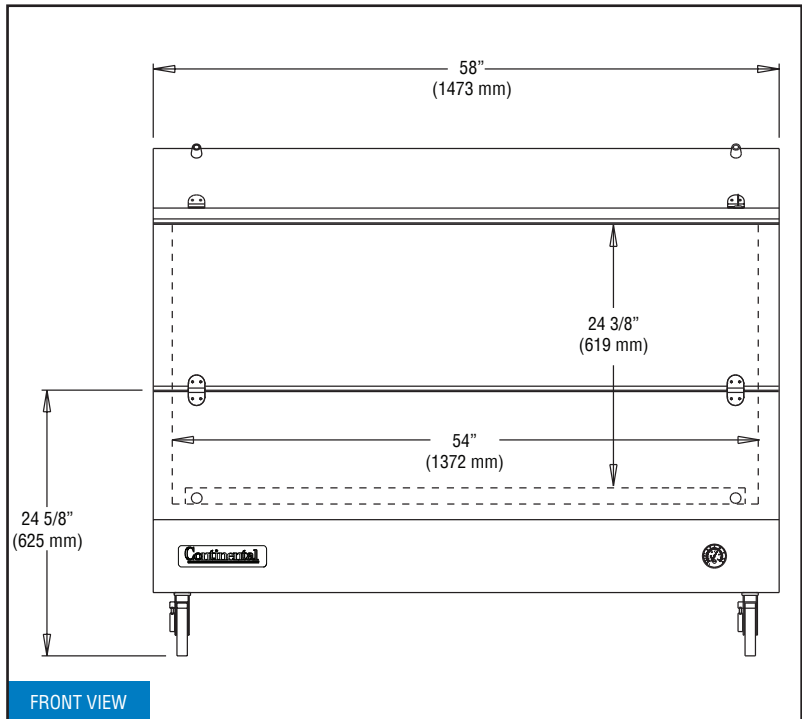

FRONT VIEW

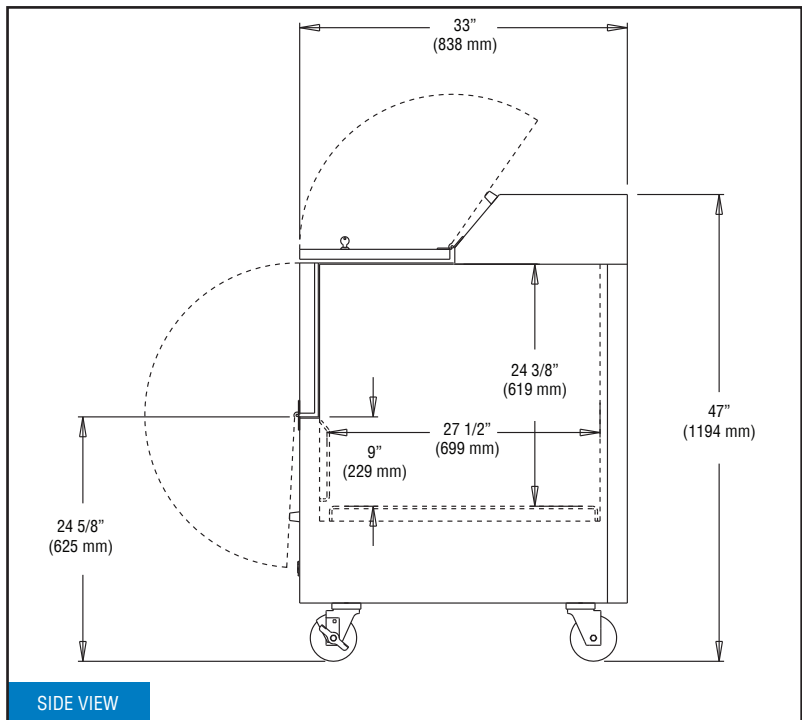

SIDE VIEW

Continental

Refrigerator

Toll-Free: 800-523-7138
 Phone: 215-244-1400
 Fax: 215-244-9579

539 Dunkserry Road
 Bensalem, PA 19020
www.continentalrefrigerator.com

Due to our continued efforts in developing innovative products, specifications subject to change without notice.



MADE IN THE U.S.A.

© Copyright 2015. Continental Refrigerator.
 A Division of National Refrigeration & Air Conditioning Products, Inc.