

BACK BAR COOLER

Model: BBC59-SGD

59" Back Bar Display Cooler with Sliding Glass Doors

Textured baked enamel finish (black) exterior, stainless steel countertop, heavy-duty galvanized steel interior side panels and top, stainless steel interior back and reinforced stainless steel floor.

Designed to maintain NSF-7 temperatures in 100°F ambient.



Options and Accessories

(upcharge and lead times may apply)

Casters or legs	Condensing unit on right
Sliding glass door lock	Wine rack
Additional epoxy-coated shelves with clips	Pass-thru
Stainless steel shelves with clips	Shallow depth
Expansion valve system	Food storage rated stainless steel interior (NSF-7)
Automatic, electric condensate evaporator	

Project Name:

Model Specified:

Location:

Item No:

Quantity:

AIA #:

SIS #:

Standard Model Features

REFRIGERATION SYSTEM

Environmentally-safe R-134a refrigerant

Performance-rated, **front breathing** refrigeration system

Automatic, energy-saving, non-electric condensate evaporator

Full length, extra large coil

CABINET ARCHITECTURE

High density, non-CFC polyurethane foamed-in-place insulation

Double pane, tempered Low-e sliding glass doors

Heavy-duty epoxy-coated steel shelves

MODEL FEATURES

Easily accessible and serviceable slide-out condensing unit

Front, rear and side venting louvered grills

LED interior lighting

Continental
Refrigerator

Toll-Free: 800-523-7138
Phone: 215-244-1400
Fax: 215-244-9579

539 Dunksferry Road
Bensalem, PA 19020
www.continentalrefrigerator.com

APPROVAL:

Model Specifications

DIMENSIONAL DATA

Net Capacity (cu. ft.)	22 (623 cu l)
Width, Overall (in.)	59 (1499 mm)
Depth, Overall (in.) (incl. top & bumpers)	28 (711 mm)
Depth, Body Only (in.)	25 (635 mm)
Height, Overall (in.)	36 3/4 (933 mm)
Barrel Capacity (# barrel type kegs)	2
Straight Wall Capacity (# straight wall kegs)	3
No. of Doors	2
No. of Shelves	4

REFRIGERANT DATA

Condensing Unit Size (H.P.)	1/3
Capacity (BTU/Hr)*	2025

ELECTRICAL DATA

Voltage (int'l)	115/60/1 (220/50/1)
Feed Wires (incl. ground)	3
Total Amps (int'l)	7.0 (3.4)
10 ft. Cord/Plug [attached] (int'l)	Yes (No)

SHIPPING DATA

Weight (lbs.)	395 (179 kg)
Height - Crated (in.)	46 (1168 mm)
Width - Crated (in.)	65 (1651 mm)
Depth - Crated (in.)	42 (1067 mm)

* Rating @ +25°F evaporator, 90°F ambient

Figures in parentheses reflect metric equivalents rounded to the nearest whole unit.



Equipped with one NEMA-5-15P Plug
(varies by country)

Model Plan Views

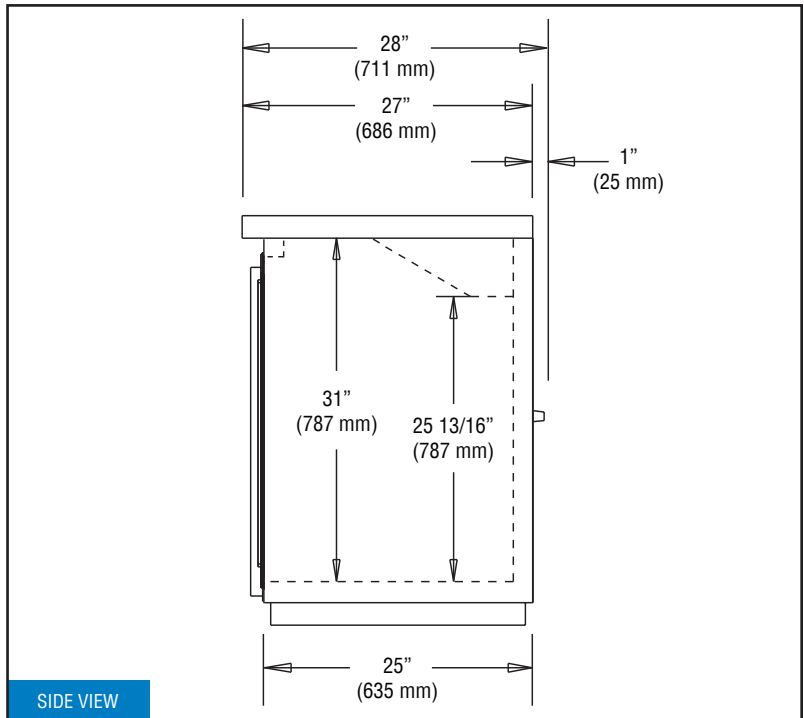
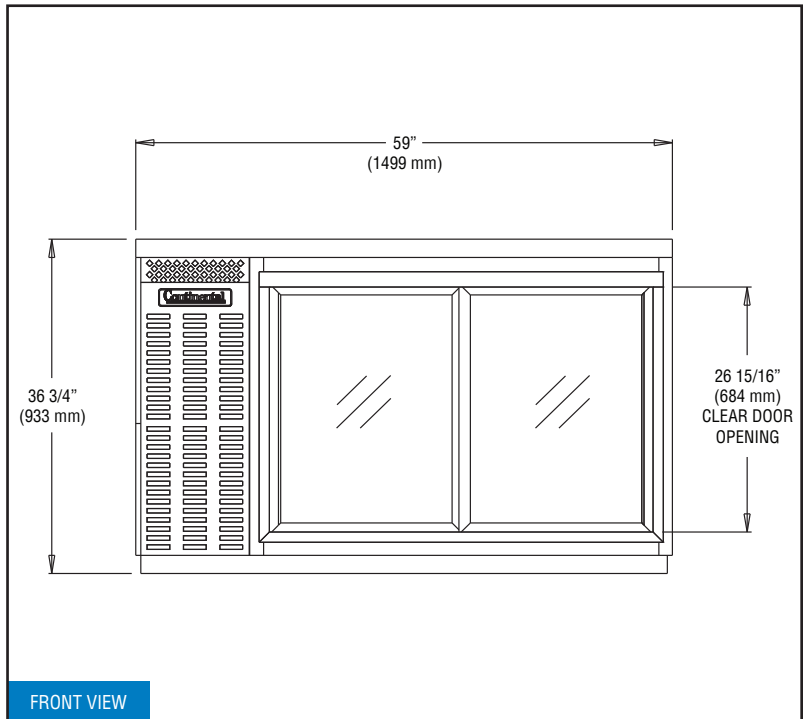

Continental
Refrigerator

Toll-Free: 800-523-7138
Phone: 215-244-1400
Fax: 215-244-9579

539 Dunkserry Road
Bensalem, PA 19020
www.continentalrefrigerator.com

Due to our continued efforts in developing innovative products, specifications subject to change without notice.



MADE IN THE U.S.A.

© Copyright 2016. Continental Refrigerator.
A Division of National Refrigeration & Air Conditioning Products, Inc.