

PRODUCT:

QUANTITY:

ITEM #:

Designed Smart

Increased Performance in Cooking

- Champion high output gas burners generate 25% more BTU's than competitive grills.
- Fast start-up to prime cooking temperatures
- Provides fast recovery and the ability to handle a variety of foods.
- Openings in the front allow the pilot light to be easily lit and adjusted without removing the front panel.

Safety Features

- Bull-nose front extension protects employees from burns.

Saves Time and Clean-up Labor Cost

- Maintenance is easier with bottom-mounted grease collection pan.
- Field convertible and adjustable gas regulator.

Built Solid

Built to Last

- Thick, stainless steel construction on front panel and top skirt protects against kitchen 'wear and tear' and rust.
- Welded construction.
- 3/4" polished steel griddle surface stands up to years of high output cooking.
- Griddle plate is fully welded to base.

Reliability backed by APW Wyott's Warranty

- All APW Wyott Champion Cooking Equipment is backed by a 3-year limited warranty and a 1-year on-site labor warranty.*
- Certified by the following agencies:



Model GGM-24H Gas Manual Griddle

APW Wyott Design Features

- 3/4" (2 cm) flat polished "hot rolled" steel griddle plate.
- 3" (7.6 cm) stainless steel backsplash; sloped side splashes.
- Front access panels for easy adjustment.
- Extended bull-nose front.
- Heavy-duty 4" (10 cm) heat-resistant, adjustable legs.
- Field convertible and adjustable gas regulator.
- Smooth action, infinitely adjustable gas valves turn 180 degrees, giving the operator ultimate control.
- Viewable standing pilot. Safety pilot available.
- Pilot can be lit without removing front panel.
- Built-in rear flue.
- Gas connections use 3/4" NPT pipe.
- 4" x 1" (10.2 cm x 2.5 cm) grease chute drains into grease drawer.
- Stainless steel grease collector drawer.

Options & Accessories

- High altitude versions are available (contact factory).
- Safety Pilot

See reverse side for product specifications.

PRODUCT:

QUANTITY:

ITEM #:

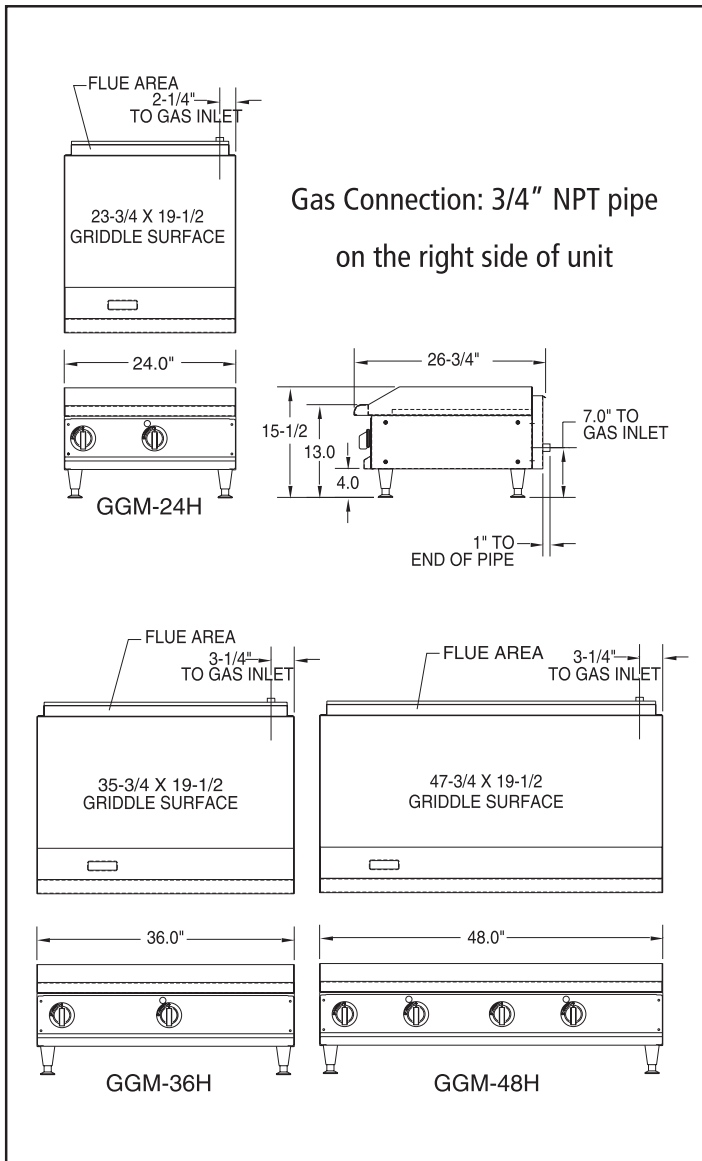

PRODUCT SPECIFICATIONS

Construction:

Stainless steel top skirt, grease through, grease collector drawer, and front panel. Aluminized steel sides and back panel. 4" adjustable legs. Welded construction, Field convertible and adjustable gas regulator.

Gas Specifications:

- GGM-18H: 1 "S" burner, 37,500 BTU/hr. One manual high-low controls. (Propane is 33,750 BTU/hr.)
- GGM-24H: 2 "U" burners, 25,000 BTU/hr. each, total 50,000 BTU/hr. input. Two manual high-low controls. (Propane is 45,000 BTU/hr.)
- GGM-36H: 3 "U" burners, 25,000 BTU/hr. each, total 75,000 BTU/hr. input. Two manual high-low controls. (Propane is 67,500 BTU/hr.)
- GGM-48H: 4 "U" burners, 25,000 BTU/hr. each, total 100,000 BTU/hr. input. Two manual high-low controls. (Propane is 90,000 BTU/hr.)

Cooking Surface:

- GGM-18H: 19 1/2" H x 23 3/4" D (49.5 cm x 60.3 cm)
- GGM-24H: 19 1/2" H x 23 3/4" D (49.5 cm x 60.3 cm)
- GGM-36H: 19 1/2" H x 35 3/4" D (49.5 cm x 90.8 cm)
- GGM-48H: 19 1/2" H x 47 3/4" D (49.5 cm x 121.3 cm)

*Grease through width: 4"

Overall Dimensions:

- GGM-18H: 15 1/2" H x 18" W x 26 3/4" D (39.4 cm x 45.7 cm x 68 cm)
- GGM-24H: 15 1/2" H x 24" W x 26 3/4" D (39.4 cm x 61 cm x 68 cm)
- GGM-36H: 15 1/2" H x 36" W x 26 3/4" D (39.4 cm x 91.4 cm x 68 cm)
- GGM-48H: 15 1/2" H x 48" W x 26 3/4" D (39.4 cm x 121.9 cm x 68 cm)

*Note: Regulator and pipe add 4 1/4" to the rear of the unit.

Shipping Information:

- GGM-18H: 200 lbs. (90.9 kg) GGM-36H: 280 lbs. (127.3 kg)
- GGM-24H: 200 lbs. (90.9 kg) GGM-48H: 355 lbs. (161.4 kg)
- F.O.B. Cheyenne, WY 82007

*APW Wyott reserves the right to modify specifications or discontinue models without incurring obligation.