

PRODUCT: _____

QUANTITY: _____

Designed Smart

Merchandising Systems!

- Smooth stainless steel front, sides, and back allow decal signs to be applied for merchandising.
- Designed to cook and hold pre-cooked foods from frozen state.
- Perfect for soups, brats, chilis, and other dishes that need a quick thaw during the cooking cycles and a gentle warming heat for serving.
- CWM model has unique “serpentine shaped” heating elements that evenly distribute heat throughout the unit.

Built Solid

Built to Last

- Heavy-duty stainless steel construction for long life.
- Steel “element support” stabilizes heating elements and reflects heat toward food.

Reliability backed by APW Wyott’s Warranty

- All APW Wyott warmers are backed by a 1 year enhanced warranty service, which replaces new units with certain product issues through the convenience of direct overnight shipments from the factory.
- Certified by the following agencies:



*inserts and lids not included on CWM-2A

Model: CWM-2A Cooker Warmer Merchandising System

APW Wyott Design Features

- All CWM versions are made with attractive stainless steel panels that have smooth surfaces.
- Designed for wet usage 100°F to 212°F (38°C to 100°C)
- BiMet thermostatic control
- Pilot light
- Side handles

CWM-2A

- Drain and side drain spicket

CWM-2V

- No Drain

CWM-2SP

- Drain and side drain spicket
- Two 7 quart insets
- Two hinged lids with clips
- Two 8 oz. ladles
- Adaptor plate with two holes for 7 quart insets



Model: CWM-2SP

See reverse side for product specifications.

PRODUCT:

QUANTITY:

Models: CWM-2A CWM-2V CWM-2SP

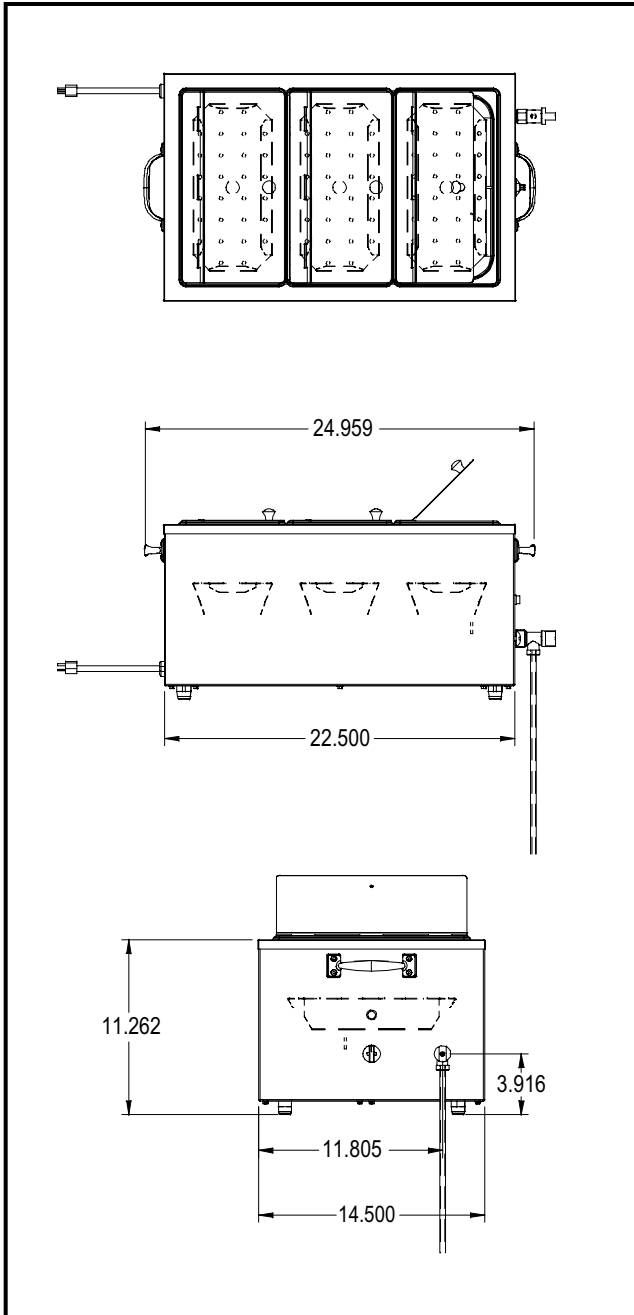

PRODUCT SPECIFICATIONS

Construction:

Stainless steel exterior and interior, chrome plated side handles, 1" bottom insulation, 1" rubber legs. Drain versions have chrome plated drain spicket.

Electrical Information:

Each unit is equipped with a 60", three wire grounded power cord which terminates with a standard three pronged male plug. The 120V unit uses a NEMA 5-15P plug.

Electrical Specifications:

CWM (all) 120V, 1500W, 12.5 Amps

Capacity:

CWM 2A/2V 22 qt. (holds one 12x20 pan or three 1/3 size pans.)
CWM 2SP Holds two 7 qt. insets

Overall Dimensions:

CWM (all) 11.26"H x 14.5"W x 22.5"D
(28.6cm x 36.83cm x 57.15cm)

Shipping:

CWM-2A 35 lbs. (13.15 kg)
CWM-2V 35 lbs. (13.15 kg)
CWM-2SP 35 lbs. (15.42 kg)

FOB: Dallas, TX 75226

Consultant Specifications

Cooker Warmer Countertop Systems (CWM) are constructed of stainless steel material around the exterior base and deep drawn stainless steel for the food well. Side handles are provided. Unit will be heated with a 1500 sepentine shaped heating element. Heat control shall be a Bi-Met thermostatic control. Each unit should have a 6 ft. long power cord and one inch rubber legs. Units with drains include a side drain spicket for easy removal of water in well. Units are UL listed, UL Sanitation, and ULC listed.

*APW Wyott reserves the right to modify specifications or discontinue models without incurring obligation.