

MODULAR UTILITY COUNTERS

QS SERIES



Item # _____ Quantity _____
 Project _____

*Quick-Ship Lead Time With
 Flexible Design Options*

OPTIONS & ACCESSORIES

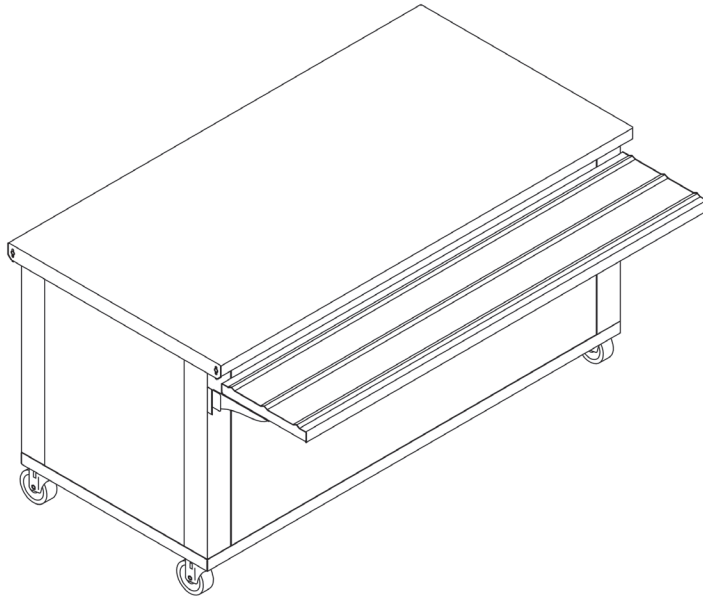

MODELS

- ULS-24-QS ULS-30-QS ULS-2-QS
- ULS-3-QS ULS-4-QS ULS-5-QS
- ULS-6-QS

- ▶ Durable welded stainless steel unibody construction
- ▶ Heavy duty 14-gauge stainless steel countertop
- ▶ Removable front and end stainless steel insert panels
- ▶ Full-length drop-down tray slide
- ▶ Grommet holes (2 ea.) in undershelf for water and electric
- ▶ Line-up Locks coupling system latches QS modules together
- ▶ 6" heavy duty casters with brakes

Service Type

- Operator service Self-service
- Two-sided island

Countertop Material

- 14-gauge stainless steel (standard)
- Zodiac® quartz Corian® solid surface

Tray Slide Options

- "V" ridge stainless steel Flat stainless steel
- Zodiac® quartz Corian® solid surface
- Stainless steel runners

Operator Work Ledge

- White poly carving board with fold-down brackets
- Stainless steel 8" work ledge with fold-down brackets

Counter Heights

- 34" high (standard) Available between 30" to 36"
- Specify _____

Hot And Cold Wells (Optional)

- 1250 watt (@ 208 V / 1 phase) drop-in (standard)
- Specify # of wells _____ Other _____

Front Inset Panels

- Stainless steel (standard) Plastic Laminate
- Graphic Panel

Food Shield (Optional)

- QS FS convertible
- Operator fixed slanted glass protector with stainless steel top shelf (std.)
- Self-serve adjustable glass with protector with stainless steel top shelf
- Self-serve with stainless steel top shelf
- Heat Lamps LED light
- End glass: Right Left

Food Shield Finishes

- Stainless steel (standard) Black powder coat

Display Shelves (Optional)

- 2-tier glass display shelf Single tier glass display shelf

Electrical Options

- Duplex outlet, flush

Other Options/Accessories

- 6" adjustable stainless steel legs
- Hinged doors Locks (hinged doors)
- Stainless steel overshelf
- Grommet holes (3") for power cords/utility services
- Hot well perimeter sheet pan recess

Plumbing Options (Optional Wells)

- Manifold drains with shut-off valve (standard)
- Individual drains
- No drains

MODULAR UTILITY COUNTERS

QS SERIES

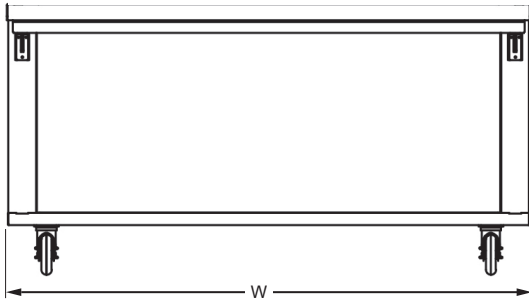

Front View ▲

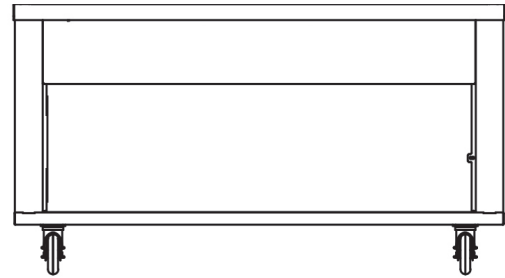

Operator View ▲



Plan View ▲

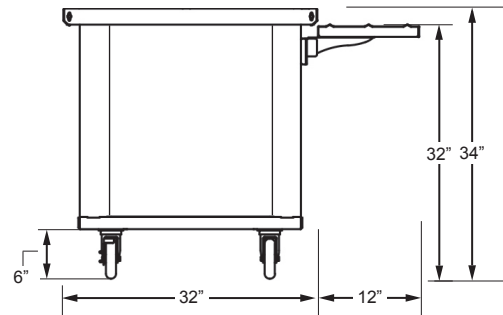

End View ▲

MODEL DETAILS

Model	Counter Size			Casters Type	Casters Dia.	Ship Wt. Lbs.
	W	D*	H			
ULS-24-QS	24"	32"	34"	All Swivel w/Brake	5"	101
ULS-30-QS	30"	32"	34"	All Swivel w/Brake	5"	126
ULS-2-QS	36"	32"	34"	All Swivel w/Brake	5"	150
ULS-3-QS	50"	32"	34"	All Swivel w/Brake	5"	210
ULS-4-QS	62"	32"	34"	All Swivel w/Brake	5"	260
ULS-5-QS	76"	32"	34"	All Swivel w/Brake	5"	318
ULS-6-QS	90"	32"	34"	All Swivel w/Brake	5"	377

*With tray slide folded down.



MULTITERIA • 1444 N FARNSWORTH AVENUE, SUITE 203 • AURORA, IL 60505
OFFICE: 630.585.1369 FAX: 630.585.1397 WWW.MULTITERIAUSA.COM

SPECIFICATIONS

Shall be Multiteria **Model ULS-__-QS** and shall be of 16-gauge stainless steel unbody construction. The front panel shall be easily removable and replaceable allowing front service access. Interior stainless steel undershelf is standard. Counter front and end insert panels shall be stainless steel and are removable for service and access. Laminate and graphic panels shall be available upon request. Counter top shall be 32" wide and fabricated of 14-gauge, #4 satin finish stainless steel with square turndown on all sides and corners fully welded, ground and polished. Drop-down tray slide shall be 14-gauge with inverted "V" ridges on surface. Ends and sides shall be turned down square with all corners fully welded and polished. Support brackets to be adjustable stainless steel drop down type. Tray slides shall have a 1/4" height adjustability. Unit is mounted on 5" swivel type casters with brakes on all wheels (6" clearance). Twist-lock latch hardware system on tray slides shall securely fasten QS counter modules together.