



**COUNTER TOP  
ELECTRIC  
PIZZA & BAKE OVENS**

Job \_\_\_\_\_ Item # \_\_\_\_\_

**ELECTRIC COUNTER TOP OVENS** 

- Model DP-2
- Model DP-2BL



**Model DP2**  
with optional top & bottom heat controls

**STANDARD FEATURES**

- DP-2 @ 5050 watts in 208V or 220-240V
- Two independent, operator controlled cook/bake chambers each with a separate set of controls
- Two 15-minute electric timers with continuous ring, audible alarms and manual shut-offs (one for each chamber)
- 300°-650°F (149°-343°C) Thermostats (one for each chamber)
- Hearth stone decks
- 5 1/2" Deck height (140mm)
- All stainless steel exterior
- Unitized, welded, aluminized steel interior
- Fully insulated
- 4" (102 mm) adjustable legs
- Interior lights
- Limited one year parts & labor warranty

**SPECIFICATIONS**

The DP-2 electric counter top ovens feature two independent, operator controlled baking chambers with 5 1/2" (140mm) deck heights and hearth stone decks making them ideal for baking and roasting or pizza. Perfect for pan pizza.

The DP-2 features two sets of controls — one set for each bake chamber. Each set consists of a 15-minute electric timer with continuous ring audible alarms and manual shut-offs, ready-on oven indicator light, and a 284-680° F (140-360°C) thermostat.

The exterior front, sides, top and door are fabricated of heavy gauge type 430 stainless steel with a #4 finish. Door handle is constructed of tubular stainless steel. Exteriors measures 26" wide (660mm) by 28" deep (711mm) by 24" tall (610mm) overall.

The interiors are constructed of high heat aluminized steel, welded to form a single unitized body. The entire oven is insulated with 1 1/2" thick (38mm) industrial grade insulation. Each hearth stone deck measures 20 3/4" (527mm) by 20 3/4" (527mm) by 1/2" thick (13mm).

Incoloy, tubular heating elements provide top and bottom heat with up to 5050 watts in 208V or 220-240V, single or three phase. International voltages available. Ovens are stackable.

Brick lining increases top heat intensity and speeds recovery.

1 Year limited parts and labor warranty included.

**OPTIONS & ACCESSORIES**

- Stainless steel stand with or without casters
- Stacking kit
- Steel decks in lieu of hearth stone
- International voltages
- Infinite controls for independent top and bottom heat control
- 4" adjustable legs
- Brick lined

**CERTIFICATIONS**



BAKERS PRIDE OVEN COMPANY, INC.  
30 Pine Street, New Rochelle, NY 10801  
914/576-0200 • 1-800-431-2745 • fax 914/576-0605

*Continuous product improvement is a policy of Bakers Pride Oven Company. Therefore, specifications and design are subject to change without notification*

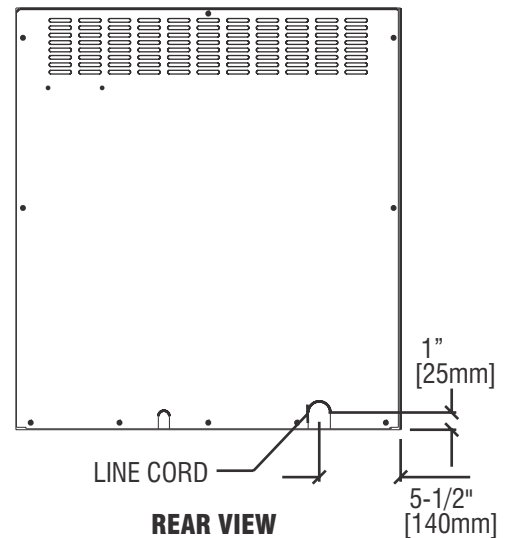
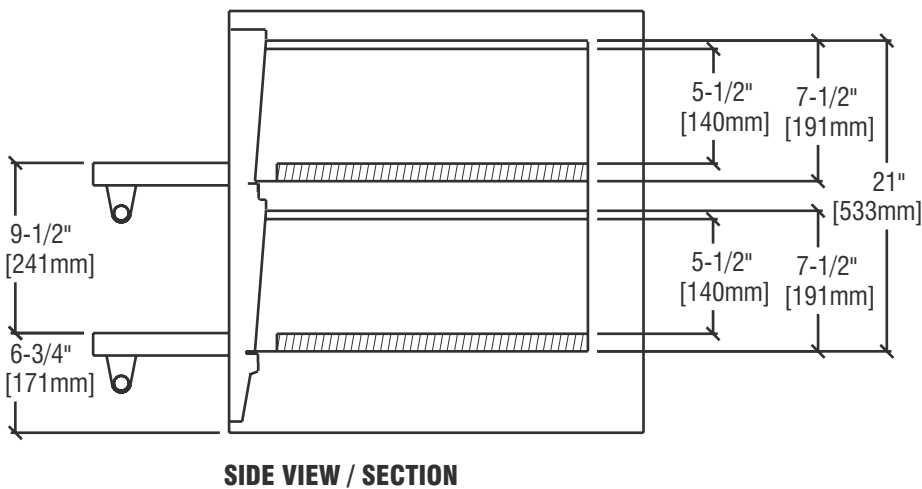
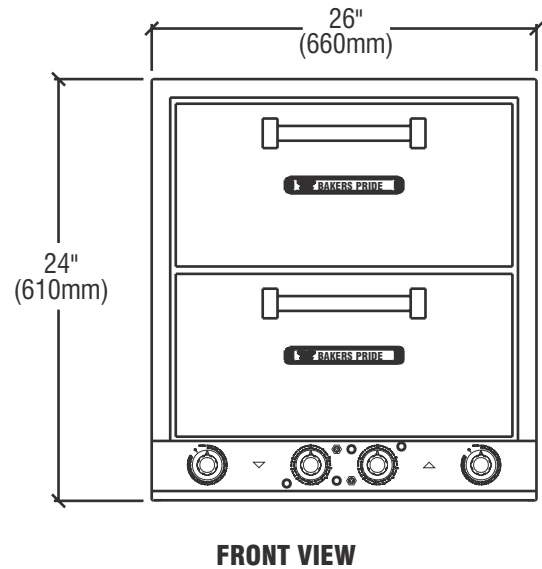
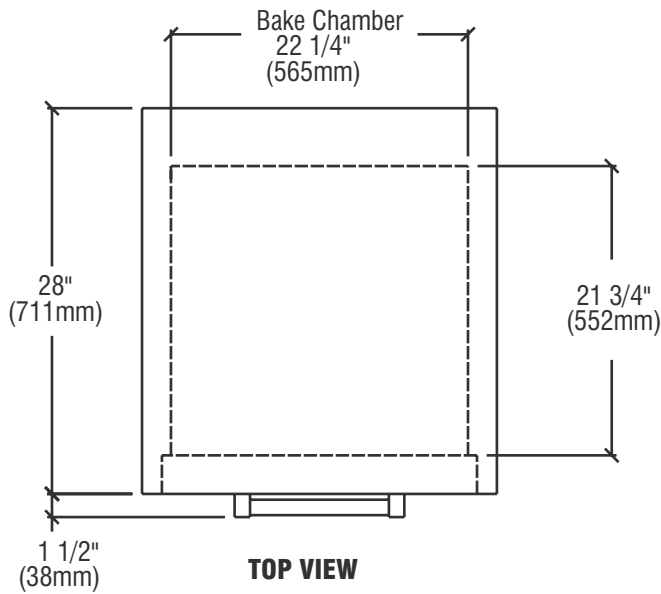

ALL DIMENSIONS NOMINAL

Model	Shipping Weight		Carton Dimensions				Crate Size			
	Lbs.	Kilos	Width Inches	mm	Depth Inches	mm	Height Inches	mm	Cubic Feet	Cubic Meter
DP-2	278	126	36	914	32 1/2	826	32	813	17.7	.51

Under 500 lbs = Shipping Class # 70

Model	WATTS	VOLTAGE	PHASE	AMPS	NEMA Plug #			
					USA	Canada	UK	Europe
DP2	5050	208	1 & 3	24.5 & 14.0	6-30P	6-30P		
DP2	5050	220-240	1 & 3	22.0 & 12.7	6-30P	6-30P		

Each oven requires a separate electrical connection.

1 Phase and Canada include cord and plug

3 Phase and International voltages has no line cord

Model	Deck Size		# Decks	# Cook Chambers	Overall Dimensions					
	Inches	mm			Width Inches	mm	Depth Inches	mm	Height* Inches	mm
DP-2	20 3/4 x 20 3/4	527x527	2	2	26	660	28	711	24	610

\* Height without legs

	Non-Combustible Construction*		Combustible Construction**	
	Inches	mm	Inches	mm
Left Side	0	0	1	25
Right Side	0	0	1	25
Rear	0	0	1	25

\* In European Community Countries and North America. In NON-COMBUSTIBLE locations only.  
 \*\* In European Community Countries only in COMBUSTIBLE locations. NOT for North America.



6-30P US & Canada

**BAKERS PRIDE**  
 BAKERS PRIDE OVEN COMPANY, INC.  
 30 Pine Street, New Rochelle, NY 10801  
 914/576-0200 • 1-800-431-2745 • fax 914/576-0605

Continuous product improvement is a policy of Bakers Pride Oven Company. Therefore, specifications and design are subject to change without notification

TSW:10/06