

TECHNICAL DATA SHEET FOR **P8M PROOFER/HOLDING CABINET** Full Size Manual / Electric

STANDARD FEATURES

- Dual function Proofer and Holding Cabinet
- Designed for individual use or system installed with Turbofan 32D Convection Ovens
- 8 full size sheet pan capacity
- 16 half size sheet pan capacity
- 3" / 76mm tray spacing
- Compact 28⁷/₈" / 735mm width
- 110-120V plug-in
- 15A NEMA 5-15P cordset fitted
- Full double skin construction
- Auto water fill system with optional integrated water filter kit
- Continuous door seal
- Side hinged door (standard LH hinge). Optional RH hinge (field convertible)
- Off / Proof / Hold mode selection
- Low velocity circulation fan system
- Mechanical thermostat
- Humidity level control
- Dual halogen cabinet interior lamps
- Cabinet temperature display thermometer
- 4 dia. 3" / 76mm castors with 2 front castors dual wheel and swivel lock, 2 rigid rear castors
- 100% recyclable packaging

ACCESSORIES

- Optional 3M Cuno water filter kit complete with cartridge and connection fittings
- Installs in pre-fitted rear housing of cabinet for flush rear installation



P8M

Unit shall be a Moffat electrically heated Turbofan Proofer and Holding Cabinet ETL Listed and NSF-4 listed. The proofer and holding cabinet shall have double skin construction with stainless steel interior and exterior sides, front and top. Door shall be side hinged and field reversible. Unit shall have capacity for up to 16 half size sheet pans or 8 full size sheet pans. A single speed fan shall gently and evenly circulate air around the cabinet. Cabinet shall be controlled by a mechanical thermostat and humidity via a control of the water tank. A thermometer shall indicate the cabinet temperature. Proofer and holding cabinet shall be mounted on castors, with two rigid castors at rear and two swivel castors dual swivel and wheel lock and front. Proofer and Holding cabinet shall operate independently or in combination with Moffat Turbofan model E32D5 or G32D5 Convection Ovens. Proofer and Holding Cabinets shall be fitted with NEMA 5-15P cordsets. Unit shall be supplied in 100% recyclable shipping packaging.

P8M Full Size Manual / Electric Proofer/Holding Cabinet

CONSTRUCTION

304 stainless steel interior cabinet
 Stainless steel front, sides and top exterior
 Stainless steel interior side racks
 Stainless steel frame side hinged door
 0.2" / 5mm thick door glass
 Stainless steel control panel
 Aluminized coated steel base and rear panels

CONTROLS

Off / Proof / Holding mode selector switch.
 Mechanical thermostat 65-185°F / 20-85°C
 Air heating ON control panel indicator
 Humidity level control
 Humidity tank ON control panel indicator
 Cabinet temperature thermometer
 Auto-fill water system standard

CLEANING

Stainless steel top and side exterior panels
 Stainless steel interior chamber
 Easy access to all interior surfaces
 Fully removable stainless steel rack support
 Removable humidity water tank (no tools)

SPECIFICATIONS

Electrical Requirements

110-120V, 50/60Hz, 1-phase, 1.45kW, 11.6A
 NEMA 5-15P cordset fitted



Water Requirements (optional)

Cold water connection 3/4" GHT male
 80psi maximum inlet pressure / 20psi minimum inlet pressure

External Dimensions

Width 28 7/8" / 735mm
 Height 36" / 914mm including dia. 3" / 76mm castors
 Depth 31 7/8" / 810mm

Proofer Internal Dimensions

Width 18 1/4" / 465mm
 Height 28 3/4" / 730mm
 Depth 27 1/2" / 700mm
 Volume 8.5ft³ / 0.24m³

Nett Weight (P8M)

171lbs / 77.5kg

Packing Data (P8M)

201lbs / 95.3kg
 26.8 ft³ / 0.76m³
 Width 30" / 760mm
 Height 42 1/2" / 1080mm
 Depth 36 3/8" / 925mm

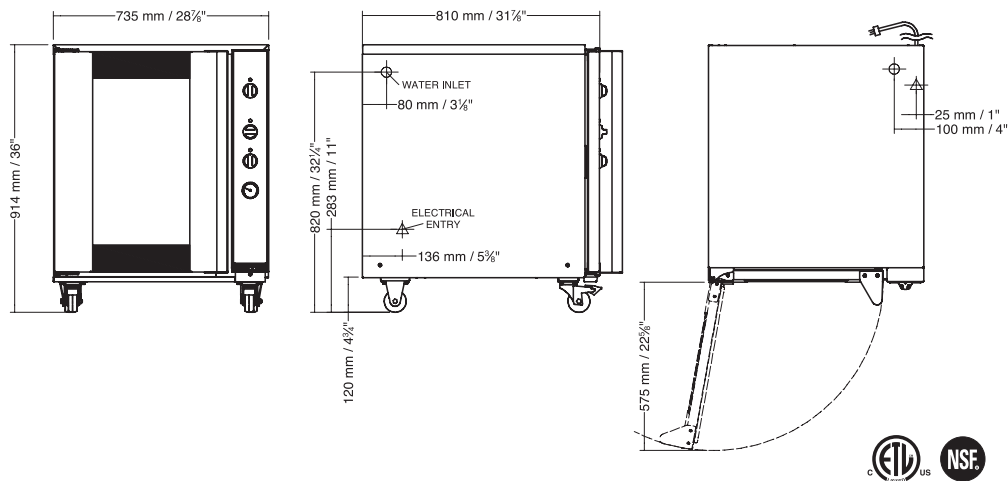

www.moffat.com

U.S.A.

Moffat Inc
 3765 Champion Boulevard
 Winston-Salem
 North Carolina 27105
 Ph Toll Free 1-800-551 8795
 Ph 336-661 0257
 Fax 336-661 9546
 Email sales@moffat.com
 www.moffat.com

Manufactured by:
 Moffat Limited
 16 Osborne Street PO Box 10-001
 Christchurch 8081 New Zealand



ISO9001
 Quality Management Standard

Designed and manufactured by
MOFFAT

ISO9001

All Turbofan products are designed and manufactured by Moffat using the internationally recognised ISO9001 quality management system, covering design, manufacture and final inspection, ensuring consistent high quality at all times.

In line with policy to continually develop and improve its products, Moffat Limited reserves the right to change specifications and design without notice.

© Copyright Moffat Ltd
 Moffat 6.10

