



BEVERAGE-AIR

Project: _____

AIA#

Item: _____

Location: _____

SIS#

Approved: _____

DD Draft Beer Equipment-Direct Draw Dispenser

DD48HC Solid Door

Hydrocarbon Series

MODELS:

DD48HC-1-B

DD48HC-1-S



DD48HC-1-B



DD48HC-1-S

**3 Year Parts/Labor Warranty
Additional 2 Year Compressor Warranty**

CABINET CONSTRUCTION

- Exterior is wear resistant vinyl on steel in black or stainless steel finish
- Top is made from heavy-duty stainless steel including drip tray
- Interior is galvanized steel on walls and ceiling, reinforced floor is heavy duty stainless steel
- Full electronic control
- Drain tube located at bottom front of cooler for connection to floor drain
- 3" Insulated dispensing towers
- Self-closing doors with locks
- Magnetic gaskets provide positive door seal
- Field reversible doors
- Compressor available on left or right, specify at time of unit order
- Maintains product temperatures between 36°F and 38°F

OPTIONS & ACCESSORIES

- 1 Half keg option
- Wine models
- Wine taps
- Faucet locks
- Glass rinser
- 3"-6" casters or 6" black legs
- 1- 5 Tap tower
- 2, 3 & 4 way manifolds
- Dual tap placement option
- No draft/hole cover option
- Remote option

REFRIGERATION SYSTEM

- Refrigeration system uses R290 refrigerant to comply with all environmental concerns
- Automatic, non-electric defrost
- Epoxy coated evaporator coil

DD48HC Direct Draw Dispenser: Standard Models



3779 Champion Blvd., Winston-Salem, NC 27105
1-888-845-9800 Fax: 1-336-245-6453
Beverage-Air.com sales@bevair.com



BEVERAGE-AIR

Bar Equipment-Direct Draw Dispenser Solid Door

Models: DD48HC-1-B, DD48HC-1-S

MODEL	DD48HC-1-B	DD48HC-1-S
EXTERNAL DIMENSIONAL DATA		
Width Overall	48"	48"
Depth Overall	24 1/2"	24 1/2"
Height Overall	51 1/4 "	51 1/4 "
Number of Doors	2	2
Depth with Door Open 90°	41 1/4"	41 1/4"
Door Opening (inches)	16 3/8" x 29 1/4"	16 3/8" x 29 1/4"
INTERNAL DIMENSIONAL DATA		
NET Capacity (cubic ft.)	12.4	12.4
Internal Width Overall (in)	36 1/8"	36 1/8"
Internal Depth Overall (in)	18 5/8"	18 5/8"
Internal Height Overall—(in)	29 3/8"	29 3/8"
Number of Kegs	2	2
ELECTRICAL DATA		
Full Load Amperes 115/60/1	2.5	2.5
REFRIGERATION DATA		
Horsepower	1/4	1/4
Capacity (BTU/Hr)*	1702	1702
WEIGHT DATA		
Gross Weight (Crated lbs)	284 lbs	304 lbs
Height - Crated	40"	42"
Width - Crated	51"	51"
Depth - Crated	26"	26"

DD48/DD50 KEG CAPACITY

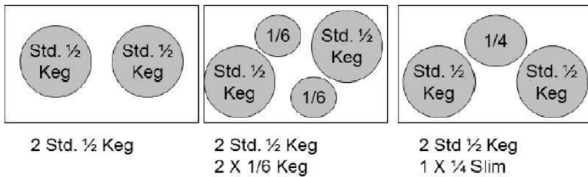

Model Views

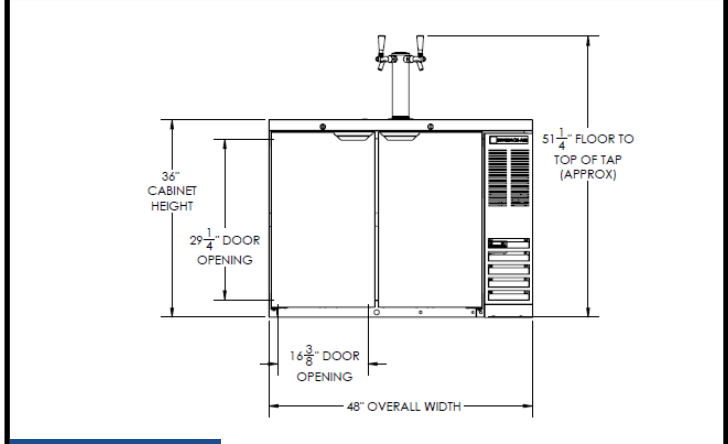
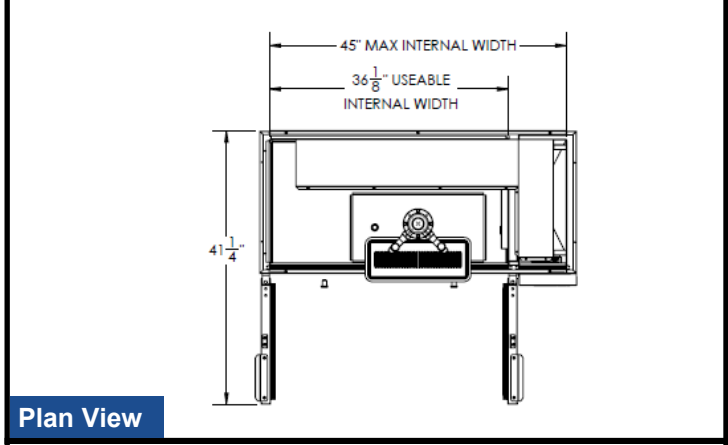

Elevation View

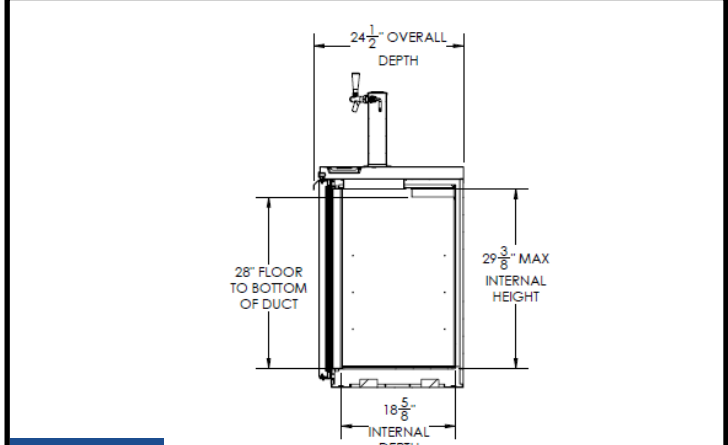

Side View

ELECTRICAL CONNECTION



115/60/1
NEMA-5-15P

Units pre-wired at factory and include 8' long cord and plug set.



an Ali Group Company



3779 Champion Blvd., Winston-Salem, NC 27105
 1-888-845-9800 Fax: 1-336-245-6453
 Beverage-Air.com sales@bevair.com