



BEVERAGE-AIR

Project: _____

AIA#

Item: _____

Location: _____

SIS#

Approved: _____

DD Draft Beer Equipment-Direct Draw Dispenser

DD58HC Solid Door Two Draft Arms, One Single & One Dual Faucets
Hydrocarbon Series

MODELS:

DD58HC-1-B

DD58HC-1-S



DD58HC-1-B



DD58HC-1-S

3 Year Parts/Labor Warranty
Additional 2 Year Compressor Warranty

CABINET CONSTRUCTION

- Exterior black or stainless steel front and door, gray painted sides
- Top and drip tray are heavy-duty stainless steel
- Interior is galvanized steel on walls and ceiling, reinforced floor and doorsills are heavy duty stainless steel
- Full electronic control
- Drain tube located at bottom front of cooler for connection to floor drain
- 3" Insulated dispensing towers
- Two (2) draft arms, one (1) with single faucet and (1) with dual faucets
- Self-closing doors with locks
- Magnetic gaskets provide positive door seal
- Field reversible doors
- Compressor available on left or right, specify at time of unit order
- Maintains product temperatures between 36°F and 38°F

OPTIONS & ACCESSORIES

- Club top models available
- Wine models
- Wine taps
- Faucet locks
- Glass rinser
- 3"-6" casters or 6" legs with adjustable plate
- 1- 5 Tap tower
- 2,3 & 4 way manifolds
- No draft/hole cover options
- Remote option

REFRIGERATION SYSTEM

- Refrigeration system uses R290 refrigerant to comply with all environmental concerns
- Automatic, non-electric defrost
- Epoxy coated evaporator coil

DD58HC Direct Draw Dispenser: Standard Models



3779 Champion Blvd., Winston-Salem, NC 27105
1-888-845-9800 Fax: 1-336-245-6453
Beverage-Air.com sales@bevair.com



BEVERAGE-AIR

Bar Equipment-Direct Draw Dispenser Solid Door

Models: DD58HC-1-B, DD58HC-1-S

MODEL	DD58HC-1-B	DD58HC-1-S
EXTERNAL DIMENSIONAL DATA		
Width Overall	59"	59"
Depth Overall with Handle	29"	29"
Height Overall	52 1/2"	52 1/2"
Number of Doors	2	2
Depth with Door Open 90°	50 1/2"	50 1/2"
Door Opening (in)	21" x 30"	21" x 30"
INTERNAL DIMENSIONAL DATA		
NET Capacity (cubic ft.)	21.86	21.86
Internal Width Overall (in)	46 1/8"	46 1/8"
Internal Depth Overall (in)	23 1/8"	23 1/8"
Internal Height Overall (in)	27 3/8"	27 3/8"
Number of Kegs	3	3
ELECTRICAL DATA		
Full Load Amperes 115/60/1	2.5	2.5
REFRIGERATION DATA		
Horsepower	1/4	1/4
Capacity (BTU/Hr)*	1702	1702
WEIGHT DATA		
Gross Weight (Crated lbs)	342 lbs	376 lbs
Height - Crated	30 1/2"	41 1/4"
Width - Crated	61"	62"
Depth - Crated	46"	30"

DD58/68/72 KEG CAPACITY:

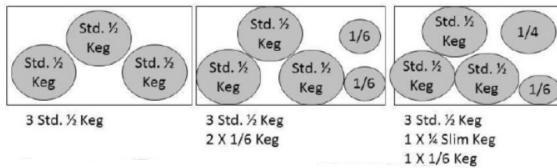

Model Views

Plan View

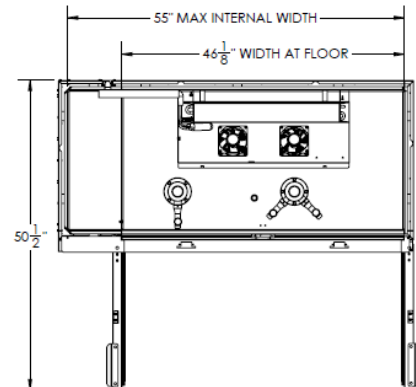

Elevation View

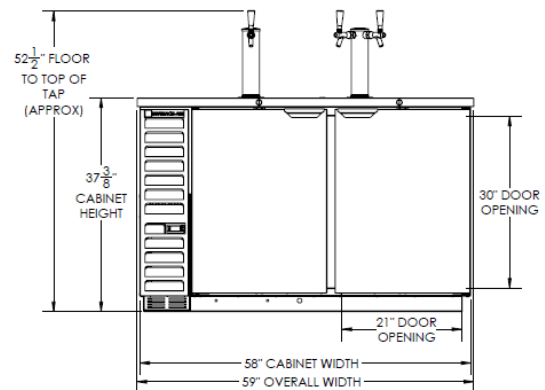

Side View

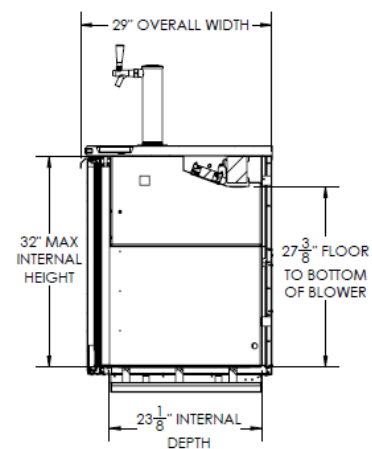

ELECTRICAL CONNECTION



115/60/1
NEMA-5-15P

Units pre-wired at factory and include 8' long cord and plug set.



an Ali Group Company



The Spirit of Excellence

3779 Champion Blvd., Winston-Salem, NC 27105
1-888-845-9800 Fax: 1-336-245-6453
Beverage-Air.com sales@bevair.com