



# BEVERAGE-AIR

PO Box 5932, Spartanburg, SC 29304  
1-888-845-9800 Fax# 1-864-582-5083  
<http://www.Beverage-Air.com>

## Commercial Refrigeration Equipment General Specification

### WTF—SERIES WORKTOP UNITS

Versatile, compact (29" deep) models with stainless steel work tops and frozen storage of food products. Working height\* is 35 1/2".

### CABINET CONSTRUCTION

Heavy duty construction includes stainless steel on front, sides, door(s) and grille. Worktop is stainless steel with 4" removable backsplash. Cabinet back and bottom are galvanized steel. Interior liner is made of anodized aluminum for longer lasting corrosion protection. Interior thermometer is standard.

Cabinets are insulated with foamed-in-place polyurethane insulation of 2" minimum thickness. Work tops are 2 1/2". Doors are mounted to cabinet on self-closing, cartridge style hinges with 120° stay open feature. Door openings include low wattage, anti-condensate heaters. A plug-in type vinyl magnetic gasket is attached to each door for positive seal. Convenient, contoured, pull handle is made of black anodized aluminum. Interior arrangement includes 2 steel wire epoxy coated shelves behind each door, adjustable in 1/2 inch increments.

### REFRIGERATION

Forced air refrigeration systems use capillary tube to meter refrigerant. Temperatures are held at zero and below. Refrigerant used is R404A. Automatic defrost is standard. Automatic (non-electric) condensate evaporator is provided.

### ELECTRICAL

Units wired at factory and ready for connection to a 115/60/1 phase, 15 amp dedicated outlet. 8' long cord and plug set included.

### SPECIAL FEATURES

- Cartridge style door hinges provides positive seal & eliminates door sagging issues (excludes glass door and some special units).
- 6" casters, two with brakes standard.
- Optional 6" legs or 3" casters available

Item No. \_\_\_\_\_

Quantity \_\_\_\_\_

## 29" DEPTH WORKTOP FREEZER FOOD PREPARATION SERIES

MODELS:  
WTF27A  
WTF48A



WTF27



WTF48

### ELECTRICAL CONNECTION

Units pre-wired at factory and include 8' long cord and plug set.



\*Note: Overall heights of casters may vary with different types of casters depending upon caster manufacturer designations.

Available From:



<b>Model Specified</b> _____	<b>Store#</b> _____
<b>Location</b> _____	<b>Quantity</b> _____



**Standard Worktop  
Freezer Cabinets**  
Models: WTF27A / WTF48A

MODEL	WTF27A	WTF48A
<b>EXTERNAL DIMENSIONAL DATA</b>		
Length Overall (inches)	27"	48"
Length Overall (mm)	686	1219
Depth Overall (inches) - Less handle	29 3/8"	30 3/4"
Depth Overall (mm) - Less handle	746	781
Height Overall—on 6" casters (inches)*	35 1/2"	35 1/2"
Height Overall—on 6" casters (mm)*	902	902
Depth with Door Open 90°	53 3/4"	52 1/4"
Clear Door Opening (inches)	22 1/2" x 23 1/4"	19 1/2" x 21 1/2"
Number of doors	1	2
<b>INTERNAL DIMENSIONAL DATA</b>		
NET Capacity (cubic ft.)	7.3	13.9
NET Capacity (Liters)	207	394
Internal Length Overall (inches)	23"	44"
Internal Length Overall (mm)	584	1118
Internal Depth Overall (inches)	25"	20"
Internal Depth Overall (mm)	635	508
Internal Height Overall (inches)	23"	23"
Internal Height Overall (mm)	584	584
Number of shelves	2	4
<b>ELECTRICAL DATA</b>		
Full Load Amperes 115/60/1	6.0	7.0
<b>ENERGY CONSUMPTION (KWH)</b>		
	7.5	10.9
<b>REFRIGERATION DATA</b>		
Horsepower	1/4	1/3
<b>WEIGHT DATA</b>		
Gross Weight (Crated lbs)	160	250
Gross Weight (Crated kg)	73	114

**PLAN VIEWS**

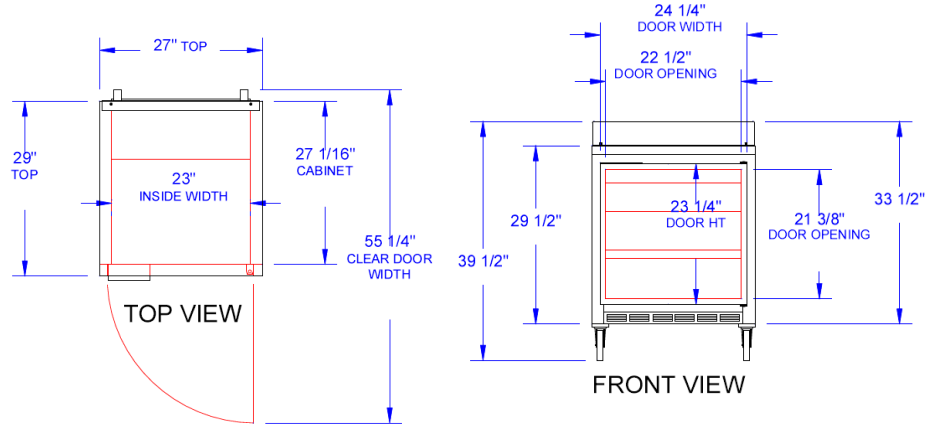

**WTF27A**

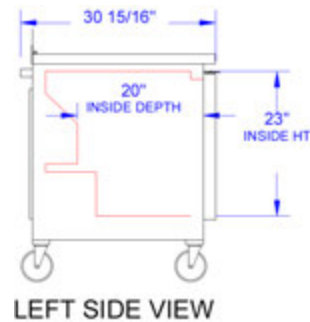

**\*Note:** Overall heights of casters may vary with different types of casters depending upon caster manufacturer designations.



**WTF48A**

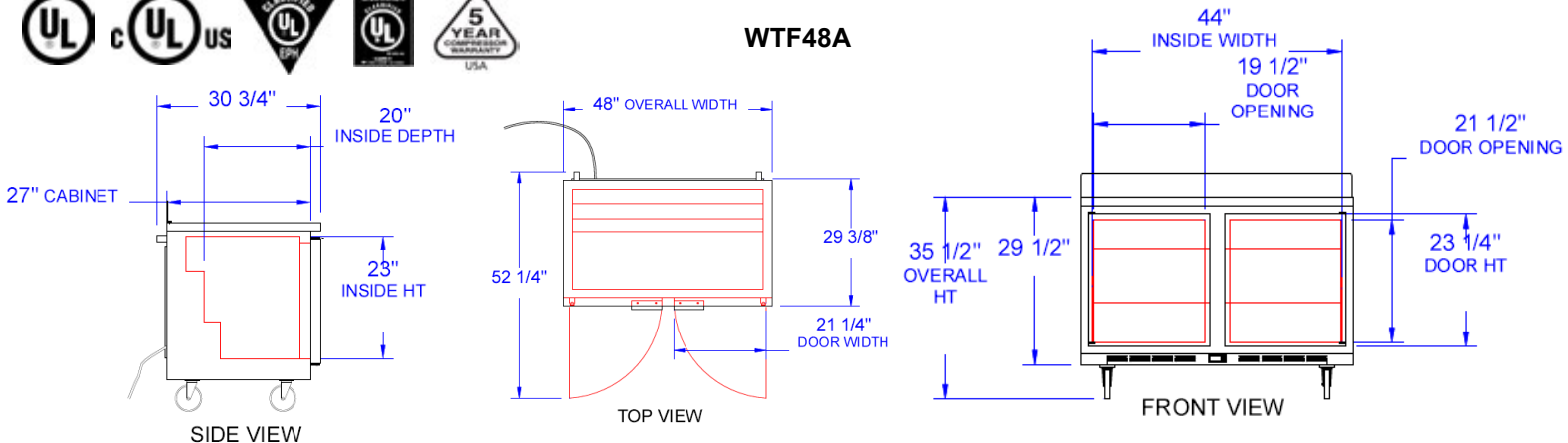

**BEVERAGE-AIR® CORPORATION**

700 Buffington Road • PO Box 5932 • Spartanburg, SC 29304 USA • (864) 582-8111 • Fax (864) 582-5083 • (888) 845-9800 • www.beverage-air.com

Specifications are subject to change without prior notice. 07/09