



Project: _____	AIA#
Item: _____	
Location: _____	SIS#
Approved: _____	

**MODELS:
DPD67-2**

DPD FOOD PREPARATION SERIES

DPD67 Deli/Pizza Prep Table with One Door and Two Drawers



DPD67-2

**3 Year Parts/Labor Warranty
Additional 2 Year Compressor Warranty**

CABINET CONSTRUCTION

- Stainless steel front, sides, top, door, drawers and grille (*galvanized back & bottom*)
- Interior liner is made of corrosion resistant aluminum
- Aluminum top interior liner prevents spill from falling into cabinet
- Stainless steel top
- Removable hoods and insulated lid assemblies are made of matching stainless steel
- Door is self-closing on cam-lift hinges
- Magnetic gaskets provide positive seal on both door and drawers
- 120° Stay-open door feature
- Field reversible door
- 3" Casters, 2 with brakes standard
- 19" Wide reversible cutting board is removable for easy cleaning
- Two epoxy-coated steel wire shelves
- Units will accept pans up to 6" deep (pans are not included)
- Drawer frames are heavy duty stainless steel
- Telescoping slides, with locking mechanism to prevent drawers from being pulled off of cabinet
- Heavy duty pan locking divider supports are standard in drawers
- Maintains product temperatures between 36° to 38°F

OPTIONS & ACCESSORIES

- Stainless steel back and grille
- Stainless steel interior
- Locks
- Bun tray rack
- Composite cutting board
- 6" Casters
- 6" Legs
- Remote option

REFRIGERATION SYSTEM

- Refrigeration system uses R134a refrigerant to comply with all environmental concerns
- Automatic, non-electric defrost
- Epoxy coated evaporator coil

DPD67 Food Preparation Series: Deli/Pizza Prep Model



3779 Champion Blvd., Winston-Salem, NC 27105
1-888-845-9800 Fax: 1-336-245-6453
Beverage-Air.com sales@bevair.com



BEVERAGE-AIR

MODEL	DPD67-2
EXTERNAL DIMENSIONAL DATA	
Width Overall	67"
Depth Overall with Cutting Board	36 1/2"
Height Overall with 3" Casters	55 1/2"
Number of Doors	1
Door Opening (in)	21 5/8" x 23 5/8"
Number of Drawers	2
Depth with Drawers Extended	55 5/8"
Drawers Opening (in)	21 5/8" x 10 3/8" 21 5/8" x 10 1/4"
Depth, Cutting Board	19"
INTERNAL DIMENSIONAL DATA	
NET Capacity (cubic ft.)	27
Internal Width Useable (in)	48"
Internal Depth Overall (in)	26"
Internal Height Overall (in)	25"
Number of Shelves	2
ELECTRICAL DATA	
Full Load Amperes 115/60/1	6.3
REFRIGERATION DATA	
Horsepower	1/4
WEIGHT DATA	
Gross Weight (Crated lbs)	410 lbs
Height - Crated	47 1/2"
Width - Crated	70"
Depth - Crated	37"

Deli/Pizza Preparation Table

Models: DPD67-2

Model Views

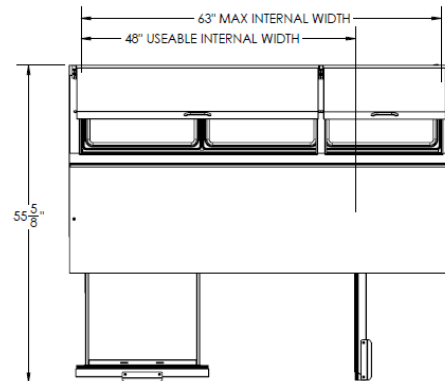

Plan View

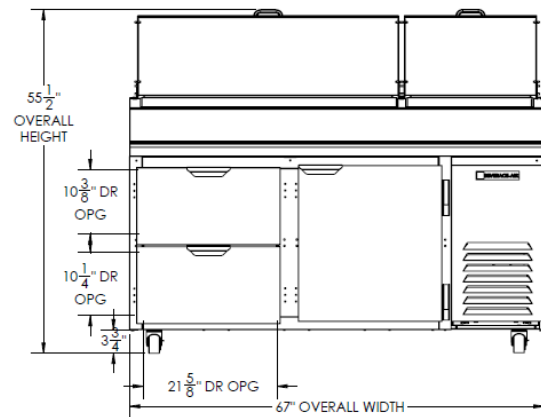

Elevation View

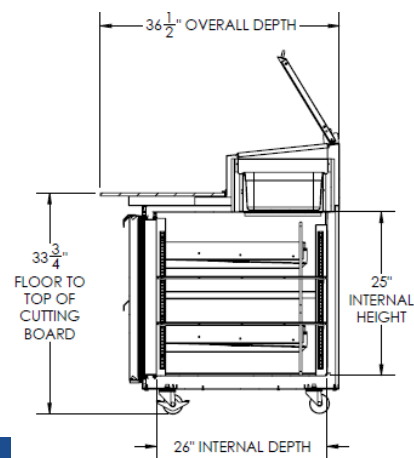

Side View

ELECTRICAL CONNECTION



115/60/1
NEMA-5-15P

Units pre-wired at factory and include 8' long cord and plug set.



an Ali Group Company



The Spirit of Excellence

3779 Champion Blvd., Winston-Salem, NC 27105
1-888-845-9800 Fax: 1-336-245-6453
Beverage-Air.com sales@bevair.com