



BEVERAGE-AIR

Project: _____	AIA#
Item: _____	
Location: _____	SIS#
Approved: _____	

STF58HC DUAL ACCESS, FORCED AIR: SCHOOL MILK SERIES

SCHOOL MILK FORCED AIR COOLER

STF58HC Dual Access Cooler
Hydrocarbon Series

MODELS:
STF58HC-1-S
STF58HC-1-W



3 Year Parts/Labor Warranty
Additional 4 Year Compressor Warranty

CABINET CONSTRUCTION

- SS units: Stainless steel exterior and interior
- White units: White coated steel exterior. Interior features galvanized walls with stainless steel floor for maximum milk crate support
- Stainless steel lids, hinges doors and door latches
- Full electronic control
- Heavy-duty epoxy coated steel wire floor racks standard
- Floor drain is centrally located for easy cleaning and connecting to drain hose with hose adapter
- Flexible compression door gaskets ensure tight seal
- Self-latching doors/lids with safety bumpers
- Exterior thermometer
- Cylinder lock
- 5" Heavy-duty plate casters (2 with locks)
- Balanced, forced-air refrigeration system provides rapid chilling of product
- Maintains continuous milk temperature between 36° - 38°F

OPTIONS & ACCESSORIES

- Stainless steel interior on white models -02
- Corner bumpers
- Graphics

REFRIGERATION SYSTEM

- Uses environmentally friendly, energy efficient R290 refrigerant, and meets all regulatory requirements for CARB, SNAP, DOE & more
- Epoxy coated evaporator coil



Please verify qualifying units by visiting:
www.energystar.gov/cfs

3779 Champion Blvd., Winston-Salem, NC 27105
1-888-845-9800 Fax: 1-336-245-6453
Beverage-Air.com Sales@bevair.com



BEVERAGE-AIR

MODEL	STF58HC (white & stainless steel models)
EXTERNAL DIMENSIONAL DATA	
Width Overall	58"
Depth Overall	34"
Height Overall with Casters	47 ³ / ₄ "
Number of Lids/Doors	Dual Access
Both Lids Extended	64"
INTERNAL DIMENSIONAL DATA	
NET Capacity (cubic ft.)	24.3
Internal Width Overall (in)	46"
Internal Depth Overall (in)	30"
Internal Height Usable (in)	24 ⁵ / ₈ "
CASE CAPACITY	
13" X 13" 11"	16
19" X 13" 11"	10
ELECTRICAL DATA	
Full Load Amperes	3.3
REFRIGERATION DATA	
Horsepower	1/3
Capacity (BTU/Hr)	2052
SHIPPING DATA	
Gross Weight - Crated lbs	496 lbs
Height - Crated	54"
Width - Crated	38"
Depth - Crated	63"

School Milk Cooler Model: STF58HC

Model Views

PLAN VIEW

ELEVATION VIEW

SIDE VIEW

*ELECTRICAL CONNECTION



115/60/1
NEMA 5-15P

Units pre-wired at factory and include 8' long cord and plug set.



3779 Champion Blvd., Winston-Salem, NC 27105 1-888-845-9800 Fax: 1-336-245-6453 Beverage-Air.com Sales@bevoir.com

an Ali Group Company



The Spirit of Excellence



BEVERAGE-AIR

Project: _____	AIA#
Item: _____	
Location: _____	SIS#
Approved: _____	

STF58HC DUAL ACCESS, FORCED AIR: SCHOOL MILK SERIES

SCHOOL MILK FORCED AIR COOLER

STF58HC Dual Access Cooler
Hydrocarbon Series

MODELS:
STF58HC-1-W-02



3 Year Parts/Labor Warranty
Additional 4 Year Compressor Warranty

CABINET CONSTRUCTION

- White coated steel exterior
- Stainless steel interior
- Stainless steel lids, hinges doors and door latches
- Full electronic control
- Heavy-duty epoxy coated steel wire floor racks standard
- Floor drain is centrally located for easy cleaning and connecting to drain hose with hose adapter
- Flexible compression door gaskets ensure tight seal
- Self-latching doors/lids with safety bumpers
- Exterior thermometer
- Cylinder lock
- 5" Heavy-duty plate casters (2 with locks)
- Balanced, forced -air refrigeration system provides rapid chilling of product
- Maintains continuous milk temperature between 36° - 38°F

OPTIONS & ACCESSORIES

- Corner bumpers
- Graphics

REFRIGERATION SYSTEM

- Uses environmentally friendly, energy efficient R290 refrigerant, and meets all regulatory requirements for CARB, SNAP, DOE & more
- Epoxy coated evaporator coil



Please verify qualifying units by visiting:
www.energystar.gov/cfs

3779 Champion Blvd., Winston-Salem, NC 27105
1-888-845-9800 Fax: 1-336-245-6453
Beverage-Air.com Sales@bevair.com



BEVERAGE-AIR

MODEL	STF58HC-1-W-02
EXTERNAL DIMENSIONAL DATA	
Width Overall	58"
Depth Overall	34"
Height Overall with Casters	47 3/4"
Number of Lids/Doors	Dual Access
Both Lids Extended	64"
INTERNAL DIMENSIONAL DATA	
NET Capacity (cubic ft.)	24.3
Internal Width Overall (in)	46"
Internal Depth Overall (in)	30"
Internal Height Usable (in)	24 5/8"
CASE CAPACITY	
13" X 13" 11"	16
19" X 13" 11"	10
ELECTRICAL DATA	
Full Load Amperes	3.3
REFRIGERATION DATA	
Horsepower	1/3
Capacity (BTU/Hr)	2052
SHIPPING DATA	
Gross Weight - Crated lbs	496 lbs
Height - Crated	54"
Width - Crated	38"
Depth - Crated	63"

School Milk Cooler Model: STF58HC-1-W-02

Model Views

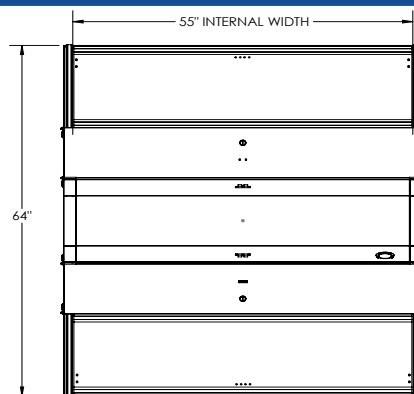

PLAN VIEW

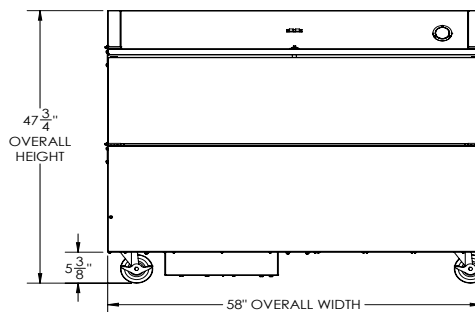

ELEVATION VIEW

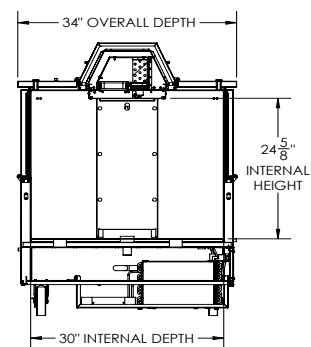

SIDE VIEW

*ELECTRICAL CONNECTION



115/60/1
NEMA 5-15P

Units pre-wired at factory and include 8' long cord and plug set.



3779 Champion Blvd., Winston-Salem, NC 27105 1-888-845-9800 Fax: 1-336-245-6453 Beverage-Air.com Sales@bevoir.com

an Ali Group Company



The Spirit of Excellence