



BEVERAGE-AIR

Project: _____	AIA#
Item: _____	
Location: _____	SIS#
Approved: _____	

UCF UNDERCOUNTER FREEZER

UCF27AHC Solid Door
Hydrocarbon Series

MODELS:
UCF27AHC

UCF27AHC Undercounter Freezer: Food Prep Series

3 Year Parts/Labor Warranty
Additional 2 Year Compressor Warranty

CABINET CONSTRUCTION

- Stainless steel front, sides, top, door, (*galvanized steel back & bottom*)
- Interior liner is made of corrosion resistant aluminum
- Full electronic control
- Undercounter feature a 1/2" thick sub-top
- Interior thermometer is standard
- Self-closing door with 120° stay-open feature, on cartridge style hinges
- Easy door removal for service and cleaning
- Magnetic gasket attached to each door for positive seal
- Painted aluminum door handle
- 6" Casters, two (2) with brakes standard
- Two epoxy-coated steel wire shelves standard
- Field reversible door
- Freezer temperatures is held at or 0°F of below

REFRIGERATION SYSTEM

- Refrigeration system uses R290 refrigerant to comply with all environmental concerns
- Automatic, non-electric evaporator
- System is serviceable from rear
- Epoxy coated evaporator coil



UCF27AHC

OPTIONS & ACCESSORIES

- Stainless steel back and grille
- Stainless steel interior
- Glass door with lock
- Solid door with lock
- 6" Legs
- 3" Casters
- Low profile casters
- Foot pedal opener



3779 Champion Blvd., Winston-Salem, NC 27105
1-888-845-9800 Fax: 1-336-245-6453
Beverage-Air.com sales@bevair.com



BEVERAGE-AIR

MODEL	UCF27AHC
EXTERNAL DIMENSIONAL DATA	
Width Overall	27"
Depth Overall	32"
Height Overall WITH 6" casters	34 5/8"
Number of Doors	1
Depth with Door Open 90°	55 1/4"
Door Opening (in)	22 5/8" X 21 5/8"
Shelf Area (sq. in)	Upper 389 11/32" Lower 322 5/8"
INTERNAL DIMENSIONAL DATA	
NET Capacity (cubic ft.)	6.03
Internal Width Overall (in)	23"
Internal Depth Overall (in)	23 1/2"
Internal Depth Useable (in)	Upper 18 1/2" Lower 15 1/2"
Internal Height Overall (in)	23"
Internal Height Usable (in)	16"
Number of Shelves	2
ELECTRICAL DATA	
Full Load Amperes 115/60/1	2.5
REFRIGERATION DATA	
Horsepower	1/3
Capacity (BTU/Hr)*	1418
WEIGHT DATA	
Gross Weight (Crated lbs)	174 lbs
Height - Crated	34"
Width - Crated	30"
Depth - Crated	32"

Undercounter Freezer

Models: UCF27AHC

Model Views

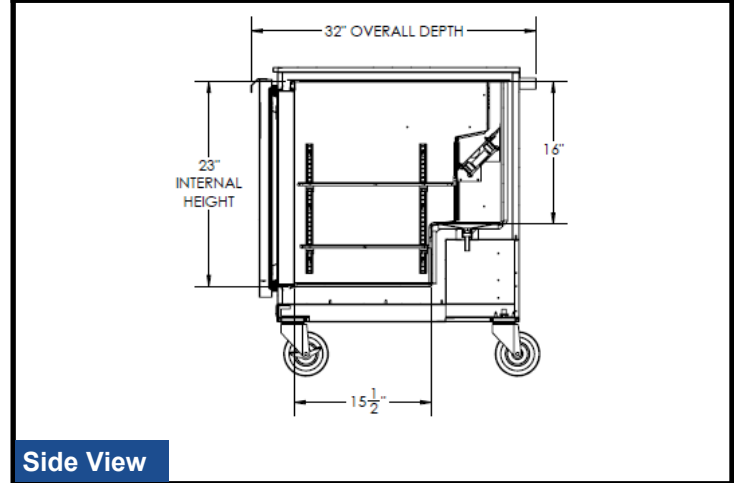
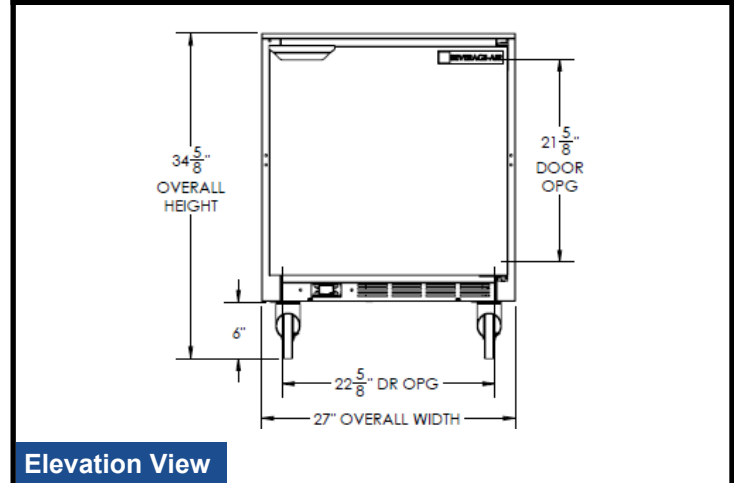
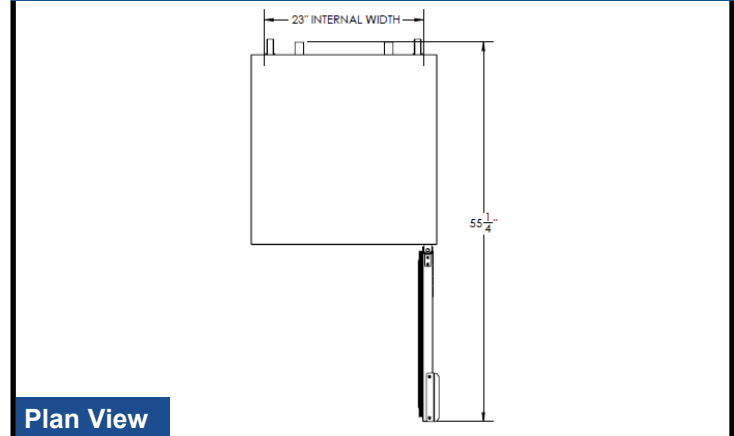

ELECTRICAL CONNECTION



115/60/1
NEMA-5-15P

Units pre-wired at factory and include 8' long cord and plug set.



an Ali Group Company



The Spirit of Excellence

3779 Champion Blvd., Winston-Salem, NC 27105
1-888-845-9800 Fax: 1-336-245-6453
Beverage-Air.com sales@bevair.com