



BEVERAGE-AIR

3779 Champion Blvd., Winston-Salem, NC 27105
1-888-845-9800 Fax# 1-336-245-6453
<http://www.Beverage-Air.com>

Commercial Refrigeration Equipment General Specification

WORKTOP CHEF BASE REFRIGERATOR

Beverage-Air's cook stand refrigerators are designed to accommodate countertop cooking equipment and feature a full marine drip-guard to prevent spills from dripping over the edge. WTRCS36 Series models are available in 2 top configurations (36" Width & 48" width) to provide the flexibility in your workspace. Refrigerated drawers provide ample food product storage. Working height of 26 3/4" on heavy-duty six-inch (6") casters.

CABINET CONSTRUCTION

Heavy-duty construction with 12 gauge stainless steel on top, front, sides, rear and drip guard top. Interior of cabinet is constructed of corrosion-resistant stainless steel. Drawers are equipped with heavy-duty workflow handle. Cabinet integrity is reinforced by use of structural columns. Cabinets are insulated with foamed-in-place polyurethane insulation of 2" thickness for added strength and maximum energy efficiency. Cabinet back and bottom are constructed of galvanized steel. Interior cabinet is made of corrosion resistant stainless steel.

WTRCS36-1 standard with marine edge. Optional flat top.
WTRCS36-1-48 standard with marine edge. Optional flat top.

Exterior solar digital thermometer with battery backup is standard.

DRAWER CONSTRUCTION

Drawer frames are constructed of heavy duty, 16 gauge stainless steel and are supported on stainless steel telescoping drawer slides with three stainless steel roller bearing wheels for maximum support of stored food product. Upper pull-out drawers accommodate two 6" deep 12" x 20" pans of combinations of 1/6 size pans or larger. Lower pull-out drawers accommodate two 4" deep 12" x 20" pans or combinations of 1/6 size pans or larger. Heavy duty pan divider supports are supplied. Foodservice pans are not included. A snap in type vinyl magnetic gasket is attached to each drawer for positive seal.

REFRIGERATION

Self-contained refrigeration system utilizes R134a refrigerant metered by a capillary tube system. Automatic (hot gas) condensate evaporation is provided. Interior forced air system, with high humidity evaporator coils, provide the ideal environment for food preservation. Removable front grille allows for easy access to complete lift-out refrigeration system.

Item No. _____
Quantity _____

WORKTOP CHEF BASE REFRIGERATORS 2 DRAWER EQUIPMENT BASE WTRCS36 SERIES

MODELS:
WTRCS36-1
WTRCS36-1-48



WTRCS36-1



WTRCS36-1-48

ELECTRICAL CONNECTION

Units pre-wired at factory and include 8' long cord and plug



*Note: Not all markings may apply to all model variations.

Available From:

Model Specified _____	Store# _____
Location _____	Quantity _____



Work top Refrigerator, Cook Stand Model Series
Models: WTRCS36-1, WTRCS36-1-48

MODEL	WTRCS36-1	WTRCS36-1-48
EXTERNAL DIMENSIONAL DATA		
Length Overall (inches)	36"	48"
Length Overall (mm)	914	1219
Depth Overall (inches)	32"	32"
Depth Overall (mm)	813	813
Height Overall— (inches)	26 3/4"	26 3/4"
Height Overall— (mm)	680	680
Number of drawers	2	2
Depth with Drawer Open 90 °	57 1/4"	57 1/4"
Upper Drawer Pans	2—12" x 20" x 6"	2—12" x 20" x
Lower Drawer Pans	2—12" x 20" x 4"	2—12" x 20" x
Top Load Rating (lbs)	800	800
Top Load Rating (kg)	363	363
INTERNAL DIMENSIONAL DATA		
NET Capacity (cubic ft.)	8.5	8.5
NET Capacity (Liters)	241	241
ELECTRICAL DATA		
Full Load Amperes 115/60/1	N/A	N/A
REFRIGERATION DATA		
Horsepower	1/5	1/5
WEIGHT DATA		
Gross Weight (Crated lbs)	225	225
Gross Weight (Crated kg)	102	102

PLAN VIEWS

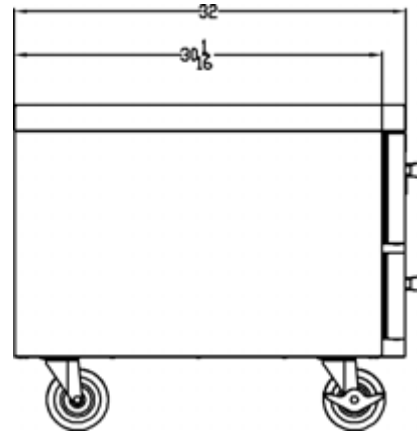

END VIEW

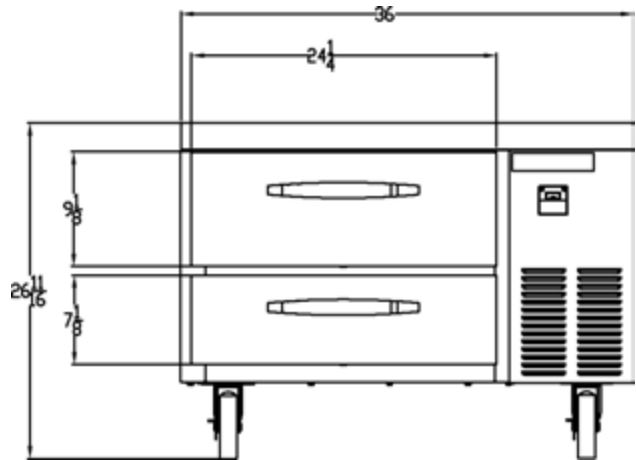

**WTRCS36-1
FRONT VIEW**



Note: Not all markings may apply to all model variations.

*N/A:: Not available at time of printing.

**WTRCS36-1
TOP VIEW**

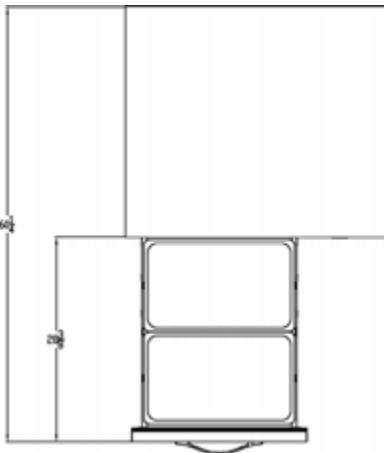

**WTRCS36-1-48
TOP VIEW**

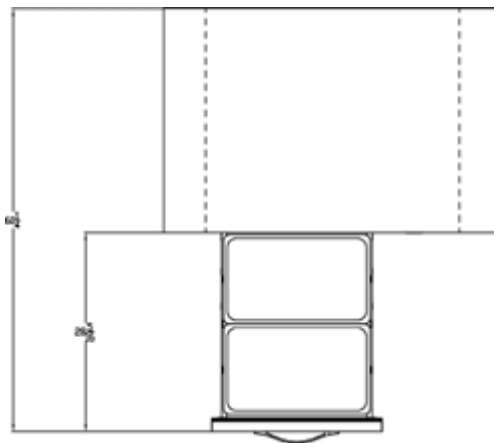

**WTRCS36-1-48
FRONT VIEW**

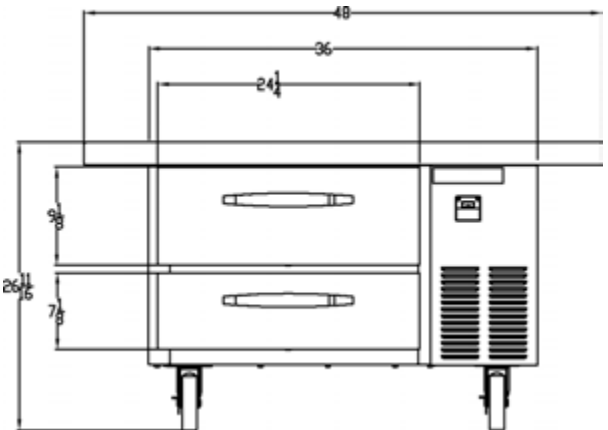

BEVERAGE-AIR® CORPORATION

3779 Champion Blvd. • Winston-Salem, NC 27105 USA • (336) 245-6400 • Fax (336) 245-6453 • (888) 845-9800 • www.beverage-air.com

Specifications are subject to change without prior notice. 11/12
 Central Restaurant Products