

SPEC # _____

QUANTITY _____

APPLICATION

ICE



AT A GLANCE

Aqua-Pure® Models ICE140-S and ICE145-S single-cartridge water filtration systems provide consistent high-quality water for commercial cubers and flakers by reducing the harmful effects of sediment, chlorine, and scale at flow rates to 2.1 gpm (7.9 lpm). Built-in scale inhibition reduces the ability of calcium and magnesium to precipitate on the evaporator plates as hard scale.

- **ICE140-S** combines chlorine taste and odor reduction with cyst, bacteria and sediment reduction, and provides protection from the harmful effects of chlorine corrosion and scale for up to 25,000 gallons (94,635 liters).
- **ICE145-S** combines chlorine taste and odor reduction with sediment reduction for higher turbidity water and provides protection from the harmful effects of chlorine corrosion and scale for up to 25,000 gallons (94,635 liters).

PRODUCT BENEFITS

- Effectively reduces sediment and chlorine for equipment protection and clearer, great tasting ice.
- Revolutionary Integrated Membrane Pre-Activated Carbon Technology ("IMPACT") dual-zone media cartridge construction combines a membrane in series with premium activated carbon to provide superior throughput and cartridge life.
- Cartridge Life Guarantee*.
- Certified by NSF to Standard 53 for cyst reduction (ICE140-S system).
- NSF Standard 42 and/or FDA CFR-21 compliance provides assurance of safety.
- The removal of over 99.99% of common water-borne heterotrophic bacteria** by membrane filtration as tested by CUNO (ICE140-S system).
- Patented† valve-in-head design simultaneously shuts off and vents water, allowing for simple and trouble-free cartridge change-outs without the need to shut off the upstream feed water.
- Built-in scale inhibitor reduces lime scale build-up on evaporator plates as tested by CUNO.
- SQC – Sanitary Quick Change – encapsulated cartridge design allows for fast and easy change-outs with a 1/4 turn while minimizing the possibility of leakage and contamination.
- 3/8" FNPT horizontal inlet and outlet ports allow direct or easily adaptable connections to existing plumbing lines.
- Exhausted cartridges may be incinerated.

PRODUCT SPECIFICATIONS

Model Number	Part Number	Reduction Claims	Micron Rating	Capacity	Service Flow Rate	Application	Replacement Cartridge	Sizing
ICE140-S	56162-03	Cyst, Bacteria, Sediment, Chlorine Taste and Odor, Scale	0.2'	25,000 gallons (94,635 liters)	2.1 gpm (7.9 lpm)	Most Normal Water	HF40-S: 56133-05	Low Flow Cubers to 1,000 lbs (454 kg) High Flow Cubers to 600 lbs (272 kg) Flakers to 1,800 lbs (816 kg)
ICE145-S	56162-04	Sediment, Chlorine Taste and Odor, Scale	3.0	25,000 gallons (94,635 liters)	2.1 gpm (7.9 lpm)	Higher Turbidity Water	HF45-S: 56133-09	Low Flow Cubers to 1,000 lbs (454 kg) High Flow Cubers to 600 lbs (272 kg) Flakers to 1,800 lbs (816 kg)

* See Aqua-Pure Commercial Products Price Book for Terms and Conditions
 ** As tested with either E. Coli ATCC (11229) or Pseudomonas (B) diminuta ATC (19146)
 † NSF Certified for Particulate, Class 1
 †† U.S. Patent #6,458,269



a 3M company



Aqua-Pure® Commercial Products

SPEC # _____
QUANTITY _____
MODEL NUMBER _____
PART NUMBER _____

Aqua-Pure®

COMMERCIAL PRODUCTS
ICE140-S/ICE145-S

PHYSICAL SPECIFICATIONS

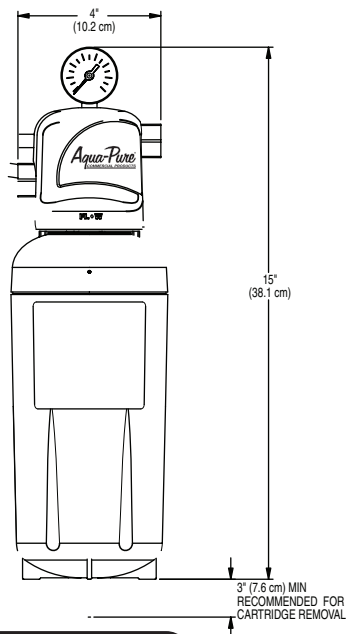

- System includes a head assembly with integral mounting bracket, pressure gauge, and a single cartridge filter.
- Inlet and outlet plumbing connections are 3/8" FNPT.
- System incorporates an internal automatic 1/4 turn shut off valve.
- Filter cartridges are double o-ring seal type.
- System maximum operating pressure of 125 psi (862 kPa) and a maximum operating temperature of 100°F (38°C).
- Recommended service flow rate is up to 2.1 gpm (7.9 lpm).
- Filter cartridges incorporate carbon block media protected by a pleated pre-filter membrane and a scale inhibitor.
- System is NSF Standard 42 and/or CFR-21 compliant.
- Cartridge body is constructed from high-impact glass-filled polypropylene.
- Cartridges are sanitary in design, requiring no contact with the filter media during cartridge change-out.
- Filter cartridges require no pre-activation.
- A NSF Performance Data Sheet (PDS) is included.
- Shipping weight: 8.9 lbs (4.0 kg) per case
- Operating weight: 6 lbs (2.7 kg)
- Case quantity: 2

INSTALLATION TIPS

- Shut off downstream equipment prior to installation of the system.
- Choose mounting location to support full system weight when operating.
- Do not exceed operating parameters for temperature or pressure.
- Do not install outdoors.
- For commercial use only.
- Install on cold water line only.

LIMITED 5 YEAR WARRANTY

CUNO makes no guarantees or warranties, expressed or implied, including, but not limited to, any implied warranty of merchantability or fitness for a particular purpose or implied warranty arising out of a course of dealing, custom, or usage of trade whatsoever with respect to these instructions. CUNO shall not under any circumstances be liable to the recipient of these instructions for any direct, indirect, special, incidental, or consequential loss or damages (including, but not limited to, loss of profits, revenue, business, opportunity, or goodwill) resulting from or in any way related to these instructions or the recipient's non-adherence to these instructions, regardless of the legal or equitable theory under which such loss or damages are sought, including breach of warranty or contract, negligence or strict liability.

IMPORTANT: Do not use with water that is microbiologically unsafe or of unknown quality without adequate disinfection before or after the system.

Systems certified for cyst reduction may be used on disinfected water that may contain filterable cysts. EPA Establishment Number 070595-CT-001.

“CAUTION” To reduce the risks associated with water leakage, which if not avoided, may result in property damage - check with your plumbing professional to verify that water pressure is less than 125 psi (862 kPa).

CUNO Incorporated recommends regularly scheduled maintenance and replacement of the filter cartridge(s) in order for the product to perform as advertised/sold. **Change the filter cartridge at least every 6 months.** CUNO shall not be liable for system failures due to improper maintenance.



Visit www.nsf.org for the claims associated with products that are NSF listed.



CUNO Incorporated
400 Research Parkway
Meriden, CT 06450, USA
Toll Free: 1.888.218.CUNO
Worldwide: 203.237.5541
Fax: 203.238.8701
www.cunofoodservice.com