



Vertical Discharge Remote Condenser

for Indigo® NXT™ Series Ice Cube Machines with R410A refrigerant

Vertical Discharge Remote Condenser for Indigo® NXT™ Series Ice Cube Machines with R410A refrigerant

Models

JCT0500

JCT1200

JCT1500

JCT1500Q (Coated Coil)



JCT1200 Remote Condenser

Standard Features

Vertical discharge remote condenser is available for Indigo NXT Series iT0500N, iT1200N, iT1500N and iT1900N ice machines. Refer to ice machine specification sheet for equipment dimensions, production capacities, electrical requirements, and ice storage bin compatibility.

Condenser operation range from -20°F (-29°C) to 120°F (49°C). Can be installed with up to 20" (50.8 cm) of bottom clearance.

Remote system consists of a remote condenser and interconnecting refrigerant lines. All components are pre-charged with refrigerant and have quick-connect fittings for convenient installation. Order ice cube machine, ice storage bin, vertical discharge remote condenser and line set separately.

Warranty

- 3-year parts and labor. See warranty statement for complete details.

Remote, air-cooled condenser system improves efficiency and ice production, conserving energy.

Manitowoc remote condenser systems effectively dissipate heat at a convenient location, indoors or outdoors, away from the ice machine. This maximizes ice-making capability and minimizes air conditioning loads by lowering the ambient air temperature at the ice machine. **For locations close to salt spray environment use coated model ("Q")**

Single Indigo Series Ice Machine	Remote Condenser
iT0500N	JCT0500
iT1200N	JCT1200
iT1500N or iT1900N	JCT1500 & Q

Installation Information and Dimensions

Maximum Location Distance - combined vertical and horizontal distances from ice machine to condenser must comply with guidelines.

Maximum Line Length: 100' (30 m)*

Maximum Vertical Rise: 35' (10.5 m) above ice machine.

Maximum Vertical Drop: 15' (4.5 m) below ice machine.

To calculate other acceptable horizontal and vertical combinations, refer to remote condenser installation instructions.

* Remote condenser has refrigerant charge for up to 50' (15 m) line length. Over 50' (15 m) requires additional refrigerant charge at time of installation.





Vertical Discharge Remote Condenser for Indigo® NXT™ Series Ice Cube Machines with R410A refrigerant

Electric

Electrical power to the remote condenser is intended to be supplied from the ice machine; however, if necessary, a separate electrical power source can be used.

Remote Indigo NXT Series Ice Machine

Indigo Model	Electrical Service*	Minimum Circuit Ampacity		Maximum Fuse size	
iT0500N	115/60/1	13.7		20	
iT1200N	208-230/60/1	10	9.5	15	15
iT1500N	208-230/60/1	14	11.3	25	20
iT1900N	208-230/60/1	17	13	25	20

* Shaded box indicates 3 phase. Consult factory.
HACR circuit breakers can be used in place of fuses.

Indigo NXT Series Remote Condensers with R410A Refrigerant

Condenser Indigo Model	Matching Ice Machine	Condenser			
		Electrical Service*	Amperage	Weight	
				lbs.	kgs.
JCT0500	iT0500N	115/60/1	1.82	64	29
JCT1200	iT1200N	208-230/60/1	1.0	67	30
JCT1500	iT1500N, iT1900N	208-230/60/1	1.0	69	31

* Consult factory. HACR circuit breakers can be used in place of fuses.

The JCT1500Q is available with coated coils for extra corrosion protection in salt spray environments. Recommend for use within 5 miles of the coast.

Standard Interconnecting Refrigerant Lines

Model	Line Length		Weight	
	ft.	m.	lbs.	kgs
R(*)-20-R-410A	20	6.07	10	4.54
R(*)-35-R-410A	35	10.67	15	6.8
R(*)-50-R-410A	50	15.24	22	9.98

*RT prefix for iT0500N and iT1200N. Order line sets separately.
*RL prefix for iT1500N and iT1900N. Order line sets separately.

The line sets above are pre-charged and come with quick connect fittings.

Typical Installation

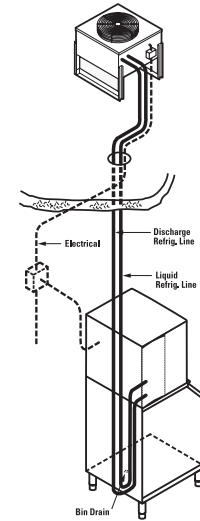

JCT0500 and JCT1200 Remote Condenser

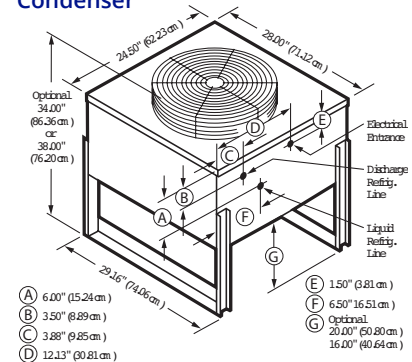

JCT1500 Remote Condenser

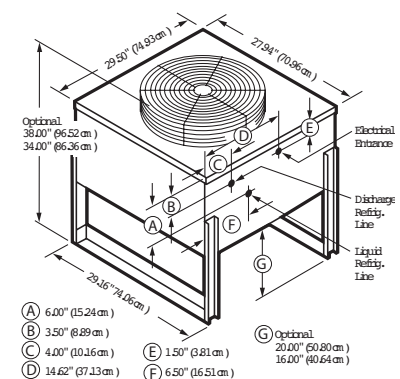

Welbilt reserves the right to make changes to the design or specifications without prior notice.