

## Portable CamBar®

### 540 Series

BAR540

BAR540DS (Designer Decor)

#### Features & Benefits

- Design combines form with function to create an efficient profit making beverage service station.
- Rounded corners and molded compartments are shock absorbent to protect valuable glassware and bottles during transport.
- Recessed work area prevents spillage and provides ample room for drink preparation.
- Seamless, double-wall, high-density polyethylene construction. Won't rust, peel, crack, chip or dent.
- Top shelf removes for easy and complete cleaning.
- Deep ice sink holds up to 80 lbs. (36,3 Kg.) of ice.
- NSF listed threaded faucet drain with standard hose hook-up is located under ice sink and provides easy draining and cleaning.
- Four each 5" (12,7 cm) swivel casters with brakes ensure easy maneuvering at any event.
- Removable towel grip speed rail holds five bottles for added convenience. Detaches for easy cleaning. Built in partitions keep bottles separated to prevent breakage.
- Non-electrical.
- No assembly required.
- Available in 7 standard colors and 3 decor combinations.
- DS Model (Designer Series)
- Decorative countertop is a granite pattern over a fiberglass composite structure for an upgraded appearance.

Item No. \_\_\_\_\_

Specifier Identification No. \_\_\_\_\_

Code No. \_\_\_\_\_

Quantity \_\_\_\_\_



# Portable CamBar®

## BAR540 Series

BAR540

BAR540DS (Designer Decor)

Item No. \_\_\_\_\_

Specifier Identification No. \_\_\_\_\_

Code No. \_\_\_\_\_

Quantity \_\_\_\_\_

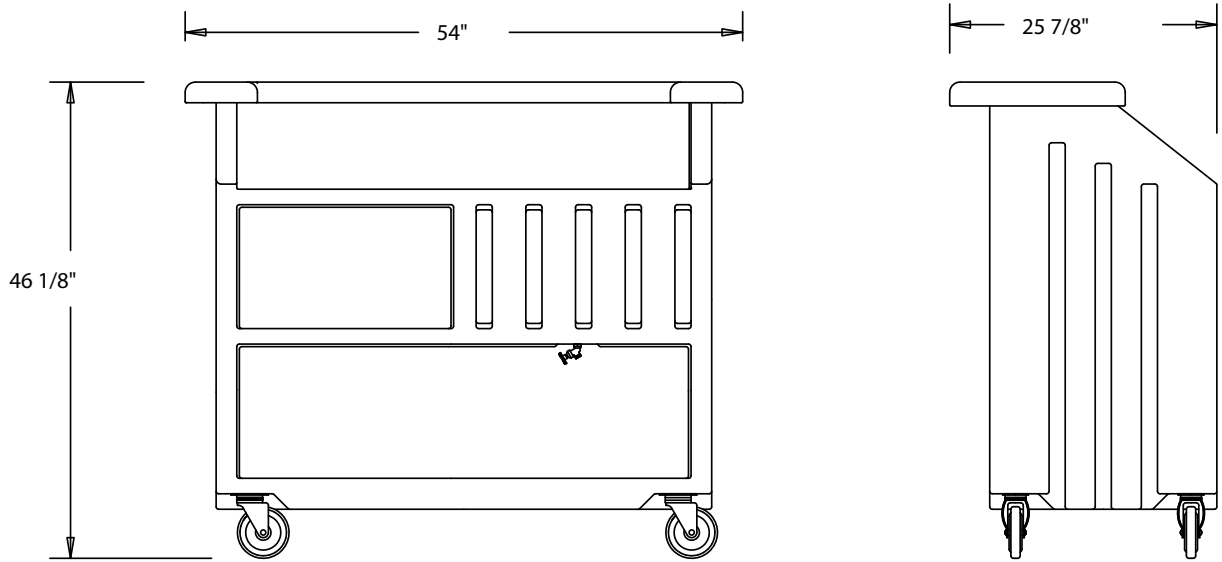

### Specifications

Dimension Tolerance: +/- 1/4" (0,64 cm)

Code	Description	Overall Dimension	Unit Weight lbs./Kg.	Shipping Case Lbs./ Cube Kg./m3
BAR540	One system equipped for bottle, can or mixer service	54" x 25 7/8" x 46 1/8" (137,2 x 65,7 x 117,2 cm)	116.5 / 52,84	138.5 (37.31) / 62,82 (1,1)
BAR540DS	One system equipped for bottle, can or mixer service (Designer Decor) with decorative counter top.	54" x 25 7/8" x 46 1/8" (137,2 x 65,7 x 117,2 cm)	123 / 55,8	145 (37.3) / 65,8 (1,1)

### Architect Specs

The non-electrical portable bar shall be a CamBar®, model BAR540 manufactured by Cambro Mfg. Co., Huntington Beach, CA 92648 U.S.A. It shall be constructed of molded high-density polyethylene and foam-injected polyurethane. It shall have 4 each 5" (12,7 cm) swivel casters w/ brakes on impact plates. It shall have one 5-bottle speedrail with a towel grip and one built-in partitions. It shall have a deep 80 lb. (36,3 Kg.) capacity ice bin with faucet drain. It shall be available in 7 standard colors and 3 decor combinations.

### Standard Colors

- Granite Gray (191)
- Granite Sand (194)
- Coffee Beige (157)
- Black (110)
- Dark Brown (131)
- Slate Blue (401)
- Gray (180)

### Designer Decor Colors

- Black Base with Coal Counter (670)
- Granite Gray Base with Slate Gray Counter (671)
- Granite Sand Base with Cocoa Counter (672)

### Speed Rail Colors

- Black (110)
- Gray (180)
- Slate Blue (401)
- Dark Brown (131)
- Granite Gray (191)
- Coffee Beige (157)
- Granite Sand (194)

# MID SIZE AND SMALL CAMBARS® – ECONOMY AND BASIC SYSTEMS

## Basic System BAR650 – Mid-Size Model Partially Equipped for Soda Service

Requires customer installation of pre-mix or post-mix soda gun system.

- Includes:**
- Sealed-in cold plate with 8 circuits
  - CO<sub>2</sub> chain
  - 7-bottle speed rail
  - 80-pound (36,3 kg) capacity ice sink
  - Ice sink cover
  - Waste-water bin
  - Retainer strap
  - 4, 6" (15,2 cm) swivel casters, 2 with brake
  - Vinyl cover

CODE	DIMENSIONS L x W x H	UNIT WEIGHT	LIST PRICE EA.
<b>Standard Decor</b>			
BAR650CP	67½" x 28½" x 47½"	285 lbs.	\$
<b>Designer Decor</b>			
BAR650DSCP	67½" x 28½" x 47½"	303	



Cold Plate

BAR650DSCP  
Shown with two optional wire racks; see details under Portable CamBar Packages & Accessories.

## Economy System BAR650 – Mid-Size Model For Bottle, Can or Mixer Service

- Includes:**
- 7-bottle speed rail
  - 80-pound (36,3 kg) capacity ice sink
  - Ice sink cover
  - Waste-water bin
  - Retainer strap
  - 4, 6" (15,2 cm) swivel casters, 2 with brake
  - Vinyl cover

CODE	DIMENSIONS L x W x H	UNIT WEIGHT	LIST PRICE EA.
<b>Standard Decor</b>			
BAR650	67½" x 28½" x 47½"	173 lbs.	\$
<b>Designer Decor</b>			
BAR650DS	67½" x 28½" x 47½"	220	



BAR650DS  
Shown with two optional wire racks; see details under Portable CamBar Packages & Accessories.

## Economy System BAR540 – Small Model For Bottle, Can, or Mixer Service

- Includes:**
- 5-bottle speed rail
  - 80-pound (36,3 kg) capacity ice sink
  - 4, 5" (12,7 cm) swivel casters, 2 with brake
  - Vinyl cover

CODE	DIMENSIONS L x W x H	UNIT WEIGHT	LIST PRICE EA.
<b>Standard Decor</b>			
BAR540	54" x 25½" x 46½"	117 lbs.	\$
<b>Designer Decor</b>			
BAR540DS	54" x 25½" x 46½"	123	



BAR540DS

### Designer Decor Colors

BAR540 Only

670 Black Base w/ Coal Counter

671 Granite Gray Base w/ Slate Gray Counter

672 Granite Sand Base w/ Cocoa Counter