

## Camtainer® Insulated Containers

### For Hot and Cold Beverages

Models 100LCD 1 gallon (3,8 L)  
250LCD 2½ gallon (9,5 L)

### For Soup (No Spigot)

Model 350LCD 3½ gallon (13,2 L)

#### Features & Benefits



- Attractive design is perfect for front-of-the-house hot and cold beverage or soup service. Stacks easily for storage and transportation.
- Serving capacity:
  - Model 100LCD - 18 each 7 oz. (210 mL) cups
  - Model 250LCD - 45 each 7 oz. (210 mL) cups
  - Model 350LCD - 64 each 7 oz. (210 mL) servings
- Single-molded, seamless, double-wall, high-density, polyethylene construction is highly durable, dishwasher safe and resists dings and dents. Textured exterior is scratch-resistant.
- Polyurethane foam insulation provides excellent hot or cold temperature retention for hours. Hot beverages remain hot without the need for a costly external heating source.
- Molded-in handles offer comfortable easy transporting.
- Recessed sturdy plastic latches will not rust or corrode and are protected from being hit or damaged.
- Drip proof recessed spigot (on 100LCD & 250LCD) allows for convenient access. Optional Easy Serve Dispenser lever attaches easily and offers easy and even beverage dispensing.
- Raised edge, spill proof rim prevents spills and leaks during transport.
- Vent cap on all models helps to equalize pressure and release steam.
- Self-adhesive beverage labels included for quick identification of contents.
- Optional Condiment Holder and Riser available for 2½ gallon (9,5 L) model.
- Optional Camdollies® offer easy transporting.
- Non-electrical.
- No assembly required.
- Available in 10 colors.

Item No. \_\_\_\_\_

Specifier Identification No. \_\_\_\_\_

Model No. \_\_\_\_\_

Quantity \_\_\_\_\_



100LCD

350LCD  
(Soup)



Easy Serve Dispenser



Spill Proof Rim and Molded-in Handle

"Camtainers Keep Beverages Hot for Hours!"

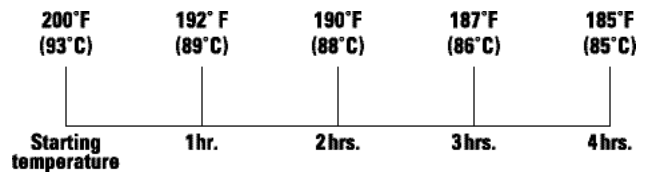

#### Approvals



# Camtainer® Insulated Containers

## For Hot and Cold Beverages

Models 100LCD 1 gallon (3,8 L)  
250LCD 2½ gallon (9,5 L)

## For Soup (No Spigot)

Model 350LCD 3½ gallon (13,2 L)

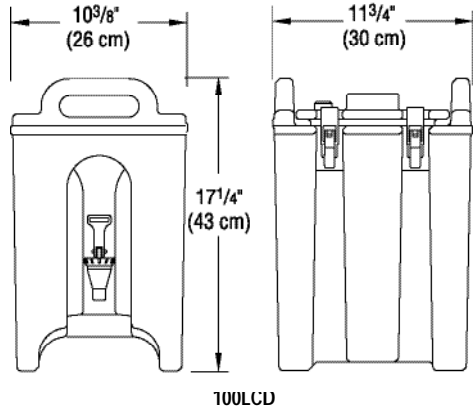

100LCD

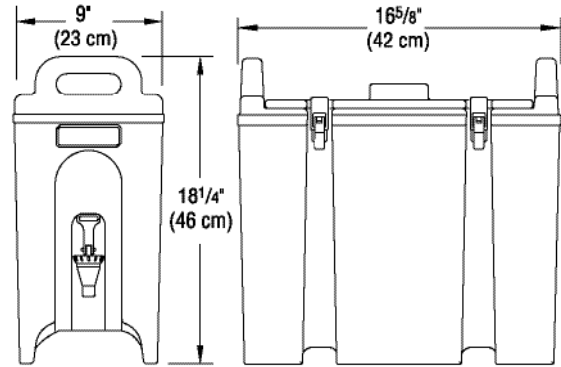

250LCD

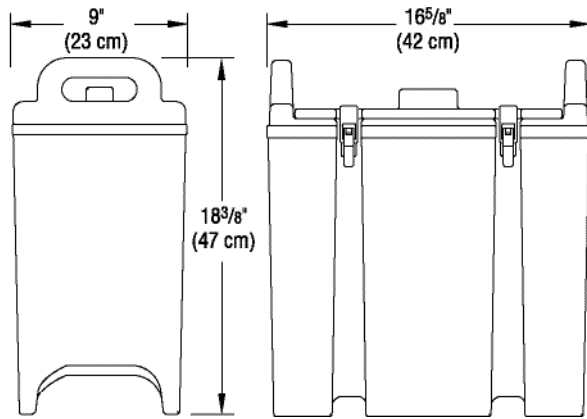

350LCD (No Spigot)

## Specifications

Dimension Tolerance: +/- 1/4" (0,64 cm)

Code	Description	Total Capacity	Serving Capacity 7 oz. (210 mL) cups	Dimensions W x D x H	Case lbs./cube Kg./m <sup>3</sup>
100LCD	Camtainer	1 gal. (3,8 L)	18	10 3/8" x 11 3/4" x 17 1/4" (26 x 30 x 43 cm)	9.5 (1.24) 4.5 (0,035)
250LCD	Camtainer	2½ gal. (9,5 L)	45	9" x 16 5/8" x 18 1/4" (23 x 42 x 46 cm)	12.75 (1.70) 6 (0,05)
350LCD	Camtainer for Soup (no spigot)	3½ gal. (13,2 L)	64	9" x 16 5/8" x 18 3/8" (23 x 42 x 47 cm)	13.25 (1.70) 6 (0,05)

## Optional Accessories

- Easy Serve Dispenser  LCDES fits 100LCD & 250LCD
- Riser  R500LCD fits 250LCD
- Condiment Holder  LCDCH fits 250LCD
- Camdolly™  CD100  CD100H fits 250LCD and 350LCD  
 CD100HB fits 250LCD and 350LCD

## Standard Colors

- Dusty Rose (400)
- Navy Blue (186)
- Slate Blue (401)
- Cold Blue (159)
- Coffee Beige (157)
- Dark Brown (131)
- Brick Red (402)
- Green (519)
- Black (110)
- Hot Red (158)

## Architect Specs

The portable, non-electrical hot and cold beverage and soup container/server shall be a Camtainer Insulated Container, Models ....., manufactured by Cambro Mfg. Co., Huntington Beach, CA 92647 U.S.A. It shall be made of one-piece, seamless, double-wall polyethylene and foam-injected polyurethane. It shall have a raised edge, spill-proof rim. It shall have a vent cap to help equalize pressure and release steam. It shall have durable, plastic latches on recessed, molded-in mounting plates. It shall have molded-in handles. It shall have a drip proof, recessed serving spigot designed with easy finger adjustment on 1

gallon (3,8 L) and 2½ gallon (9,5 L) container. It shall have the option of an Easy Serve Dispenser lever. It shall be available without a spigot for soup service. It shall have self-adhesive beverage labels to use for quick product identification. It shall have an optional Condiment Holder and Riser except for the 100LCD. It shall require no assembly and shall be offered in 10 colors.

## Approvals



© 2002 Cambro Manufacturing Company 5801 Skylab Road, Huntington Beach, California 92647-2056-U.S.A.  
Telephone (1)714 848 1555 Toll Free 800 854 7631 Customer Service Hot Line 800 833 3003

Printed in USA