

Camtainer® Insulated Containers

Models 500LCD 5 gallon (18,9 L)
1000LCD 10 gallon (37,9 L)

Features & Benefits



- Attractive design is perfect for front-of-the-house hot and cold beverage service. Stacks easily for storage and transportation.
- Serving capacity:
 - Model 500LCD - 91 each 7 oz. (210 mL) cups
 - Model 1000LCD - 182 each 7 oz. (210 mL) cups
- Single-molded, seamless, double-wall, high-density, polyethylene construction is highly durable, dishwasher safe and resists dings and dents. Textured exterior is scratch-resistant.
- Polyurethane foam insulation provides excellent hot or cold temperature retention for hours. Hot beverages remain hot without the need for a costly external heating source.
- Molded-in handles offer comfortable easy transporting.
- Recessed plastic latches will not rust or corrode and are protected from being hit or damaged. Molded-in mount plates prevent latches from pulling out.
- Drip proof recessed spigot allows for convenient access. Optional Easy Serve Dispenser lever attaches easily and offers easy and even beverage dispensing.
- Raised edge, spill proof rim prevents spills and leaks during transport.
- Vent cap on all models helps to equalize pressure and release steam.
- Self-adhesive beverage labels included for quick identification of contents.
- Optional Condiment Holder and Riser available for both models.
- Optional Camdollies® offer easy transporting.
- Non-electrical.
- No assembly required.
- Available in 10 colors.

Item No. _____

Specifier Identification No. _____

Model No. _____

Quantity _____



1000LCD
(Shown with Riser)

500LCD
(Shown with
Condiment Holder
and Riser)

250LCD
(See pg. 2)



Easy Serve Dispenser



Spill Proof Rim and Molded-in Handle.

"Camtainers Keep Beverages Hot for Hours!"

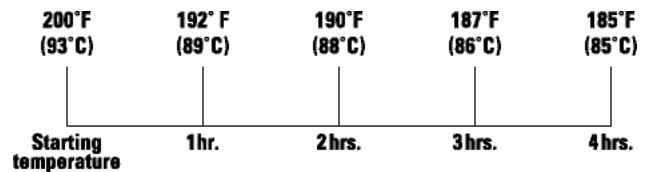

Approvals



Camtainer® Insulated Containers

Models 500LCD 5 gallon (18,9 L)
1000LCD 10 gallon (37,9 L)

Item No. _____

Specifier Identification No. _____

Model No. _____

Quantity _____

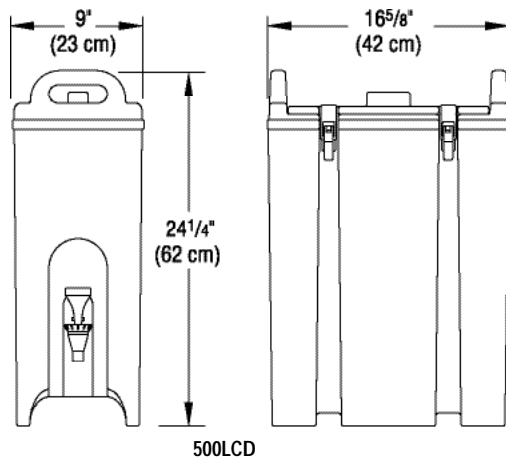

500LCD

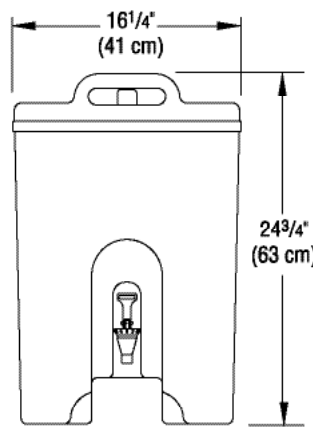

1000LCD

Specifications

Dimension Tolerance: +/- 1/4" (0,64 cm)

Code	Description	Total Capacity	Serving Capacity 7oz. (210 mL) cups	Dimensions W x D x H	Case lbs./cube Kg./m ³
500LCD	Camtainer	5 gal. (18,9 L)	91	9" x 16 5/8" x 24 1/4" (23 x 42 x 62 cm)	16 (2,24) 7,5 (0,06)
1000LCD	Camtainer	10 gal. (37,9 L)	182	16 1/4" x 20 1/16" x 24 3/4" (41 x 53 x 63 cm)	29,75 (5,31) 13,6 (0,14)

Optional Accessories

- Easy Serve Dispenser LCDES
- Riser R500LCD fits 500LCD
 R1000LCD fits 1000LCD
- Condiment Holder LCDCH fits 500LCD
 LCDCH10 fits 1000LCD
- Camdolly™ CD100 CD100H fits 500LCD
 CD100HB fits 500LCD
 CD300 CD300H fits 1000LCD
 CD300HB fits 1000LCD

Standard Colors

- Dusty Rose (400)
- Cold Blue (159)
- Brick Red (402)
- Hot Red (158)
- Navy Blue (186)
- Coffee Beige (157)
- Green (519)
- Slate Blue (401)
- Dark Brown (131)
- Black (110)

Architect Specs

The portable, non-electrical hot and cold beverage containers/server shall be a Camtainer Insulated Container, Models..., manufactured by Cambro Mfg. Co., Huntington Beach, CA 92648 U.S.A. It shall be made of one-piece, seamless, double-wall polyethylene and foam-injected polyurethane. It shall have a raised edge, spill-proof rim. It shall have a vent cap to help equalize pressure and release steam. It shall have durable, plastic latches on recessed, molded-in mounting plates. It shall have molded-in handles. It shall have a drip proof, recessed serving spigot designed with easy finger adjustment. It shall have the option of an Easy Serve Dispenser lever. It shall have self-adhesive beverage labels to use for quick product identification. It shall have an optional Condiment Holder and Riser. It shall require no assembly and shall be available in 10 colors.

Approvals



© 2002 Cambro Manufacturing Company 5801 Skylab Road, Huntington Beach, California 92647-2056-U.S.A.
Telephone (1)714 848 1555 Toll Free 800 854 7631 Customer Service Hot Line 800 833 3003

Printed in USA