

## Food Bars

### Table Top

Models 6FBRTT - 6 ft. (182 cm), 5FBRTT - 5 ft. (162 cm)  
4FBRTT - 4 ft. (130 cm)

#### Features & Benefits



- Easily turns any 4 - 6 foot (122 - 182 cm) table into a profit producing food bar. Beautifully showcases cold food offerings and/or beverages.
- Will accommodate 3 - 5 each GN 1/1 Full Size Food Pans, and Fractional Size Food Pans with Divider Bars.
- Double-wall polyethylene construction provides extra strength, durability and reliability. Scratch-resistant textured exterior. Simple to clean - just wipe off.
- Thick foamed-in-place polyurethane insulation maintains food temperatures and holds ice cold for hours. Provides added structural strength.
- Drain plug is included to offer quick and easy clean up.
- Standard accessories include protective sneeze guard, made from NSF listed material. Accommodates self-service from both sides.
- Optional accessories include Divider Bars, Crock Holder, and Salad Bowl Holders.
- Non-electrical.
- Easy to assemble.
- Available in 15 colors.

Item No. \_\_\_\_\_

Specifier Identification No. \_\_\_\_\_

Model No. \_\_\_\_\_

Quantity \_\_\_\_\_



5FBRTT

### Set Up Guide for Table Top Food Bars

#### Salad Bowls and Crockes

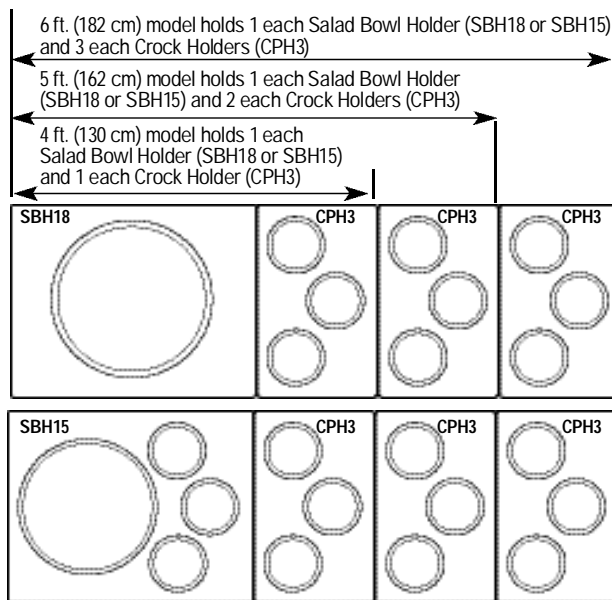

#### Food Pans

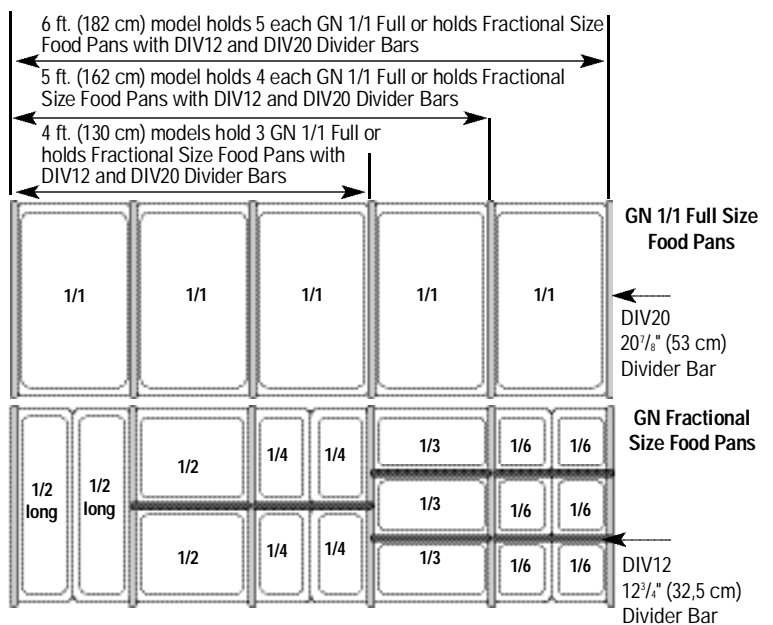

SBH18 - Holds 1 each 18" (45,7 cm) Salad Bowl  
SBH15 - Holds 1 each 15" (38 cm) Salad Bowl & 3 each 1.5 qt. (1,4 L) or 2.7 qt. (2, 4 L) Crockes  
CPH3 - Holds 3 each 1.5 qt. (1,4 L) or 2.7 qt. (2, 4 L) Crockes

### Approvals



# Food Bars

## Table Top

Models 6FBRTT - 6 ft. (182 cm), 5FBRTT - 5 ft. (162 cm)  
4FBRTT - 4 ft. (130 cm)

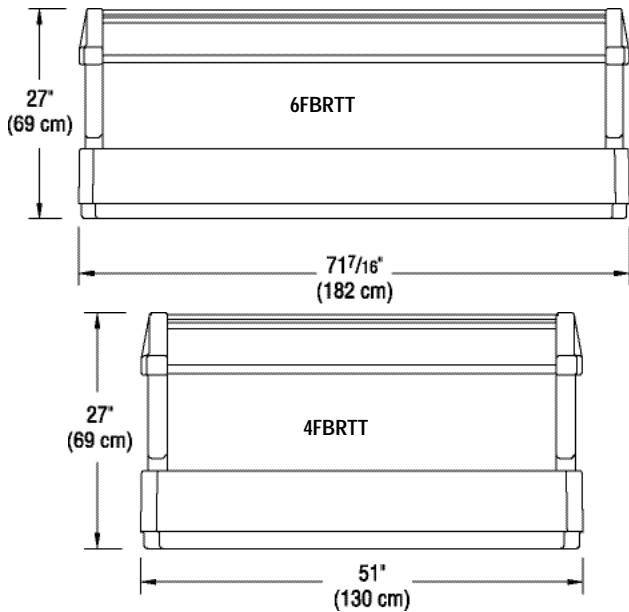

Item No. \_\_\_\_\_

Specifier Identification No. \_\_\_\_\_

Model No. \_\_\_\_\_

Quantity \_\_\_\_\_

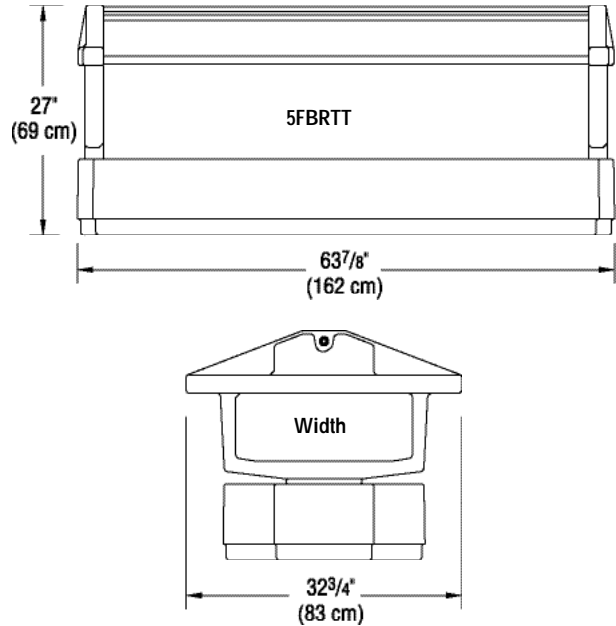

## Specifications

Dimension Tolerance: +/- 1/4" (0,64 cm)

| Code   | Description                       | GN 1/1 Full Size Food Pan Capacity | Exterior Dimensions L x W x H                  | Case lbs./cube Kg/m <sup>3</sup> |
|--------|-----------------------------------|------------------------------------|--|----------------------------------|
| 6FBRTT | 6 ft. (182 cm) Table Top Food Bar | 5                                  | 71 7/16" x 32 3/4" x 27"<br>(182 x 83 x 69 cm) | 111 (17.57)<br>50,5 (0,49)       |
| 5FBRTT | 5 ft. (162 cm) Table Top Food Bar | 4                                  | 63 7/8" x 32 3/4" x 27"<br>(162 x 83 x 69 cm)  | 98 (16.26)<br>45 (0,455)         |
| 4FBRTT | 4 ft. (130 cm) Table Top Food Bar | 3                                  | 51" x 32 3/4" x 27"<br>(130 x 83 x 69 cm)      | 85 (16.26)<br>39 (0,455)         |

## Optional Accessories

- Divider Bars**     DIV12     DIV20
- 3-Crock Holder**     CPH3 (holds 1.5 qt. (1,4 L) and 2.7 qt. (2,4 L) crocks)
- Salad Bowl Holders**     SBH15 (holds one 15" (38 cm) bowl, 3 crocks)  
 SBH18 (holds one 18" (45,7 cm) bowl)

## Standard Colors

- Black (110)     Slate Blue (401)     Brick Red (402)
- Coffee Beige (157)     Dark Brown (131)     Cold Blue (159)
- Navy Blue (186)     Dusty Rose (400)     Gray (180)
- Green (519)     Hot Red (158)     Granite Gray (191)
- Granite Green (192)     Granite Red (193)     Granite Sand (194)

### Divider Bar:

- White (148)     Clear (035)

### Crock Holder and Salad Bowl Holder:

- White (148)

## Architect Specs

The non-electrical foodservice Table Top Food Bar shall be Model..., manufactured by Cambro Mfg. Co., Huntington Beach, CA 92648 U.S.A. It shall be made of double-wall, high-density polyethylene and shall be foam-injected with polyurethane insulation. It shall range in length from 4 - 6 feet (130 - 182 cm). It shall accommodate 3 - 5 each GN 1/1 Full Size Food Pans or Fractional Size Food Pans with Divider Bars. It shall have a drain plug. It shall hold optional Cambro Salad Bowl Holders (SBH18 and SBH15) and Crock Holder (CPH3). The depth of the interior food wells shall be 6 1/2" (16,5 cm). It shall include a sneeze guard and protective end panels made of NSF listed material. It shall require minimal assembly and shall be available in 15 colors.

## Approvals

