

## Equipment Stand

### Standard Tray Rail Height

Models ES28, ES28R, ES28L, ES28RL

### Low Tray Rail Height

Models ES28RS, ES28LS, ES28RLS

#### Features & Benefits

- Perfect for cash registers or computers at the end of a school lunch line or for completing any self-serve buffet or salad bar concept.
- Increases food preparation area for microwave ovens, slicers and other appliances.
- Available with or without side rails, or with side rails to the left, right or on both sides of center drawer.
- Handy center drawer slides open to conveniently store cash, customer receipts or equipment accessories.
- Open bottom shelf features a cut out design so that the operator can sit or stand comfortably without bumping ankles or knees.
- Tough one-piece, seamless, double-wall, high-density, polyethylene construction. Polyurethane foam insulation provides greater strength and durability.
- Easy to clean and will not dent, crack, rust, chip or break.
- Tray rails are available in two convenient heights, 34 1/2" (88 cm) and 27 1/2" (70 cm), to accommodate service for both adults and children.
- Separate 2 1/2" (6,4 cm) opening through both top and bottom shelves allows cords and plugs to drop safely and neatly to the floor.
- Four each 5" (12,7 cm) casters, 2 fixed, 2 swivel w/ brakes, offer smooth maneuvering across a lunchroom floor or across campus.
- Non-electrical.
- No assembly required.
- Available in 13 colors.

Item No. \_\_\_\_\_

Specifier Identification No. \_\_\_\_\_

Model No. \_\_\_\_\_

Quantity \_\_\_\_\_



ES28R  
(Standard Tray Rail Height)



ES28R  
(Standard Tray Rail Height)



ES28RLS  
(Low Tray Rail Height)



ES28RL  
(Standard Tray Rail Height)

#### Approvals



# Equipment Stand

## Standard Tray Rail Height

Models ES28, ES28R, ES28L, ES28RL

## Low Tray Rail Height

Models ES28RS, ES28LS, ES28RLS

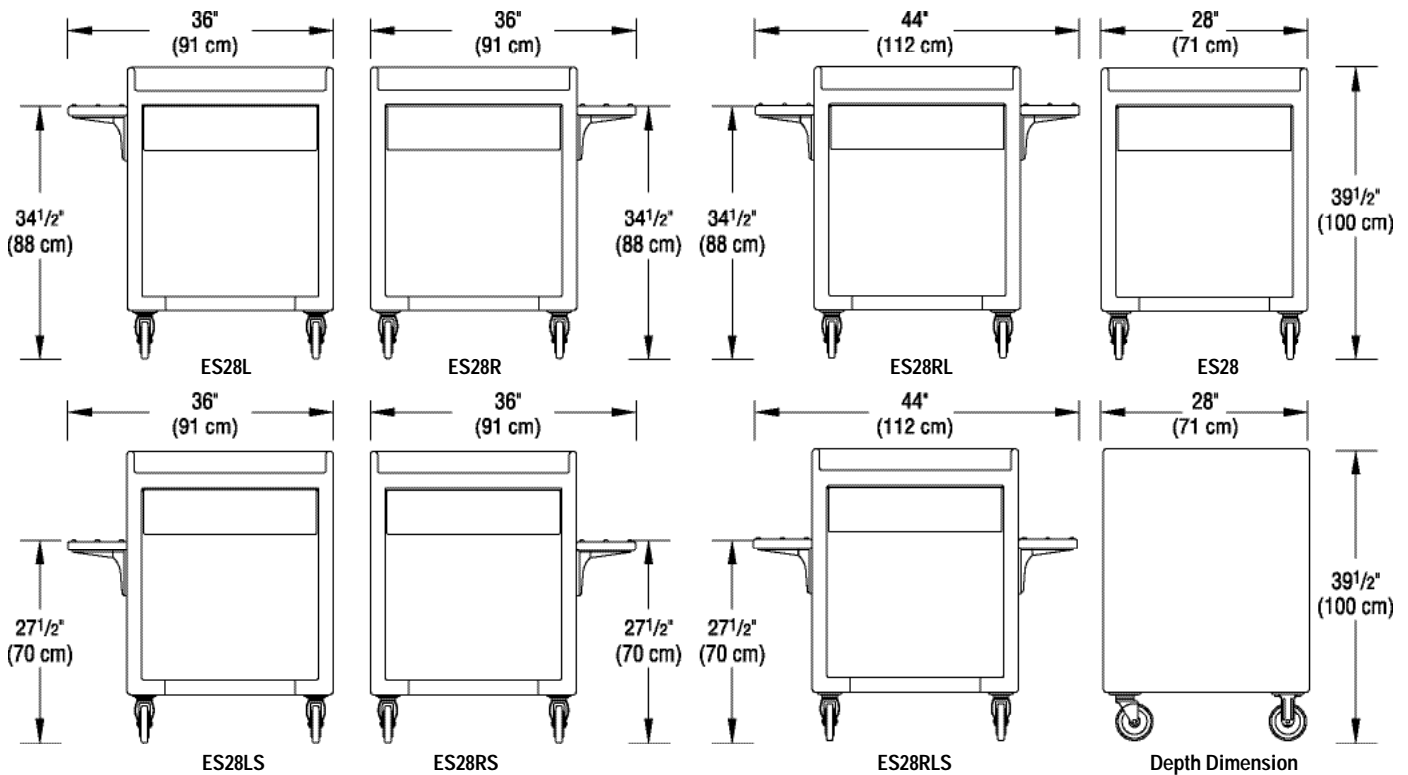

## Specifications

Dimension Tolerance: +/- 1/4" (0,64 cm)

Code	Description	Dimensions W x D x H (w/Tray Rails and Casters)	Case lbs./cube Kg/m <sup>3</sup>	Code	Description	Dimensions W x D x H (w/Tray Rails and Casters)	Case lbs./cube Kg/m <sup>3</sup>
<b>Standard Model</b>				<b>Low Model</b>			
ES28	Stand only	28" x 28" x 39 1/2" (71 x 71 x 100 cm)	76 (19,15) 35 (0,54)	ES28RS	Stand w/Rail on right side	36" x 28" x 39 1/2" (91 x 71 x 100 cm)	83 (19,15) 38 (0,54)
ES28R	Stand w/Rail on right side	36" x 28" x 39 1/2" (91 x 71 x 100 cm)	83 (19,15) 38 (0,54)	ES28LS	Stand w/Rail on left side	36" x 28" x 39 1/2" (91 x 71 x 100 cm)	83 (19,15) 38 (0,54)
ES28L	Stand w/Rail on left side	36" x 28" x 39 1/2" (91 x 71 x 100 cm)	83 (19,15) 38 (0,54)	ES28RLS	Stand w/Rails on right and left sides	44" x 28" x 39 1/2" (112 x 71 x 100 cm)	89 (19,15) 41 (0,54)
ES28RL	Stand w/Rails on right and left sides	44" x 28" x 39 1/2" (112 x 71 x 100 cm)	89 (19,15) 41 (0,54)				

## Architect Specs

The portable merchandising equipment cart shall be an Equipment Stand, Model..., manufactured by Cambro Mfg. Co., Huntington Beach, CA 92648 U.S.A. It shall be made of one-piece, seamless, double-wall polyethylene and foam-injected polyurethane. It shall be available with or without side tray rails and the tray rails shall be available in both 34 1/2" (88 cm) standard height and 27 1/2" (70 cm) low height. It shall have a central drawer. It shall have an open compartment shelf, designed with a cut out section for operator comfort, and also offering convenient storage. It shall have 4 each 5" (12,7 cm) casters, 2 fixed, 2 swivel w/ brakes. It shall have a separate 2 1/2" (6,4 cm) opening through both top and bottom shelves for cords and plugs to drop through. It shall be available fully assembled and in 13 colors.

## Standard Colors

- Black (110)
- Coffee Beige (157)
- Gray (180)
- Granite Gray (191)
- Granite Sand (194)
- Dusty Rose (400)
- Dark Brown (131)
- Brick Red (402)
- Granite Green (192)
- Slate Blue (401)
- Cold Blue (159)
- Hot Red (158)
- Granite Red (193)

## Approvals



© 2002 Cambro Manufacturing Company 5801 Skylab Road, Huntington Beach, California 92647-2056-U.S.A.  
Telephone (1)714 848 1555 Toll Free 800 854 7631 Customer Service Hot Line 800 833 3003

Printed in USA