

CamKiosk® Hand Sink Cart

Domestic Model KSC402

International Model KSC402220



Features & Benefits

- Stands alone for hand washing. Also attaches to the CamKiosk Main Cart with the optional Connector Bridge to help expand menu options.
- Double-wall, high-density, polyethylene construction is impact resistant and will not dent, crack, bubble, chip or break. Can be wiped or steam cleaned.
- Polyurethane foam-insulation provides added strength and durability.
- Two compartment stainless steel sink. Faucet runs cold water and hot water up to 140°F (60°C). Faucet is NSF-61 listed.
- Two 5 gallon (18,9 L) fresh water tanks and two 7.5 gallon (28,4 L) refuse tanks provide approximately 70 hand washings. Tanks are easy to insert and remove for emptying and refilling.
- Hot water heater has a 2.5 gallon (9,5 L) capacity and heats water in 10 minutes. 110 volt outlet required. International model available in 220 volt.
- Water pump is NSF listed. Water pump and water heater are UL approved. Each draw a maximum of 0.7 amps and 11.25 amps respectively. Hand sink cart electrical system runs on average 10 amps.
- Molded-in handles on both sides provided comfortable easy transporting.
- Four 6" (15,2 cm) casters, 2 fixed, 2 swivel w/ brakes allow for easy transport across a lobby floor, lunchroom or campus grounds.
- Paper towel holder and soap dispenser included.
- Electrical 110 volt or 220 volt.
- Some assembly required.
- Available in 7 solid colors and 2 color combinations.

Item No. _____

Specifier Identification No. _____

Model No. _____

Quantity _____



KSC402



KSC402



2-Compartment Stainless Steel Sink



Tanks and Hot Water Heater

Approvals



Water Pump and Water Heater only



Water Pump only

CamKiosk® Hand Sink Cart

Domestic Model KSC402
International Model KSC402220

Item No. _____

Specifier Identification No. _____

Model No. _____

Quantity _____

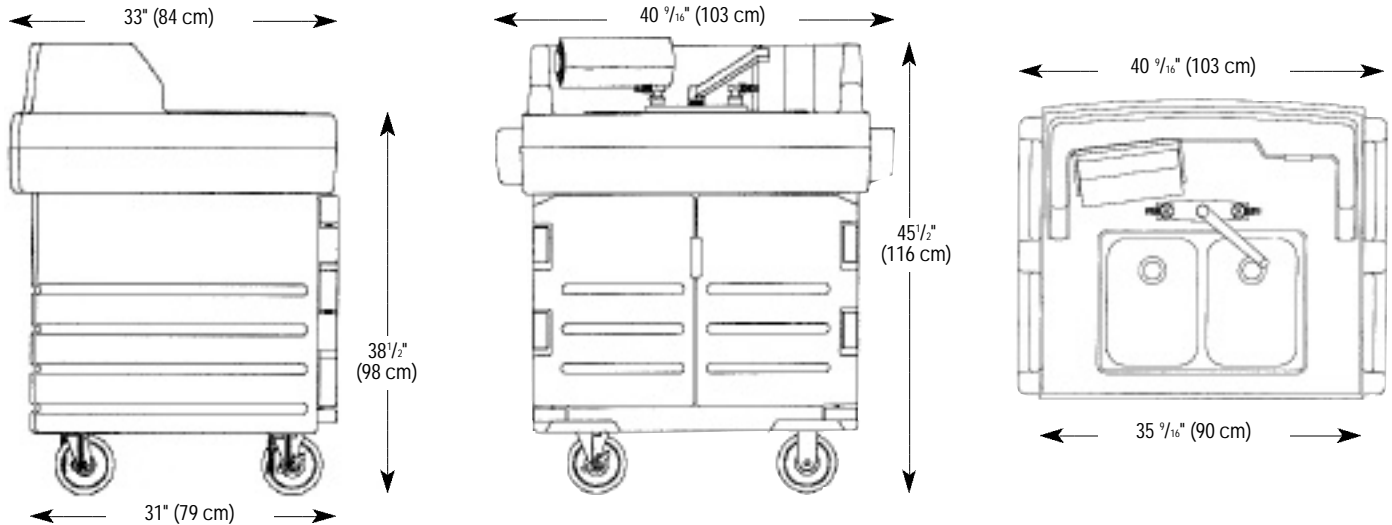

Specifications

Dimension Tolerance: +/- 1/4" (0,64 cm)

Code	Description	Overall Dimensions W x D x H	Case lbs./cube Kg/m ³
Domestic (110 volt) KSC402	2 Compartment Hand Sink Cart	40 9/16" x 33" x 45 1/2" (103 x 84 x 116 cm)	224 (39.5) 102 (1.1)
International (220 volt) KSC402220	2 Compartment Hand Sink Cart	40 9/16" x 33" x 45 1/2" (103 x 84 x 116 cm)	224 (39.5) 102 (1.1)

Optional Accessories

Connector Bridge with Front Panel KMC24
37" x 27" x 10" (94 x 68,8 x 25,4 cm)

*Note: For attaching to Camkiosk Cart only.

Standard Colors

- Granite Gray (191)
- Granite Sand (194)
- Kentucky Green (519)
- Black Base with Granite Gray Top & Door (426)
- Granite Green (192)
- Navy Blue (186)
- Granite Green Base with Black Top (425)
- Granite Red (193)
- Hot Red (158)

Architect Specs

The portable, electrical Hand Sink Cart shall be a CamKiosk Electrical Hand Sink Cart, manufactured by Cambro Mfg. Co., Huntington Beach, CA 92648 U.S.A. It shall be a Cambro Model KSC402. It shall be made of polyethylene and foam-injected polyurethane. It shall have molded-in handles, 4 ea. 6" (15,2 cm) swivel casters, 2 fixed, 2 w/ brake. It shall have a 2-compartment stainless steel sink with a faucet that runs cold and hot water up to 140°F (60°C). It shall have 2 each 5 gallon (18,9 L) fresh water tanks, 2 each 7 1/2 gallon (24,4 L) refuse tanks and one 2.5 gallon (9,5 L) hot water heater, ...volt, UL Approved. The water pump shall be UL Approved and NSF listed. Water pump and water heater shall draw a maximum of 0.7 amps and 11.25 amps respectively. Hand Sink Cart electrical system shall run on average 10 amps. It shall include a paper towel holder and soap dispenser and shall be available in 9 color options.

Approvals



Water Pump and Water Heater only



Water Pump only



© 2002 Cambro Manufacturing Company 5801 Skylab Road, Huntington Beach, California 92647-2056-U.S.A.
Telephone (1)714 848 1555 Toll Free 800 854 7631 Customer Service Hot Line 800 833 3003

Printed in USA