



Item No. \_\_\_\_\_

## Camtherm® Bulk Food Cabinets, Hot Only

Specifier Identification No. \_\_\_\_\_

### Tall Profile, Dutch Door, Single Cavity

Model No. \_\_\_\_\_

*External Fahrenheit Thermometer*

Quantity \_\_\_\_\_

Model CMBH1826TSF, CMBH1826TBF

*External Celsius Thermometer*

Model CMBH1826TSC, CMBH1826TBC



#### Features & Benefits

- Unique and versatile plastic-based electric cart is designed for both holding and transporting food on or off-premise. Food remains at safe serving temperatures. Holds hot food temperatures without electrical source for hours.
- Electric unit located on back of unit is completely enclosed in a protective, powder coated, steel encasement. When the power is on, it will maintain the air temperature inside the cavity at an even range of 150°F (65°C) to 165°F (74°C) in accordance with HACCP guidelines. When heated to 165°F (74°C) and then turned off for passive holding or transporting, the temperature inside the cavity stays above 140°F (60°C) for 8 hours when the cabinet is full. Electrical cord length is 10' (305 cm) and there is a wrapping hook for easy storage.
- Easy-to-use control panel includes a virtually unbreakable, polycarbonate waterproof cover, on-off power switch, temperature setting dial, auto green light for "power on" indicator and auto red light for "temperature achieved."
- Internal thermometer on lower door with a solar powered external digital display available in either Fahrenheit or Celsius so cavity temperatures can be checked at a glance.
- Double wall, polyethylene external construction is impact resistant and will not dent, crack, bubble, chip or break. Thick, polyurethane foam insulation helps to ensure excellent food temperature retention during holding and transporting.
- Includes anodized aluminum uprights and 12 sets of easy to remove chrome plated steel slide rails for full size food pans and/or 18" x 26" (45,7 x 66 cm) sheet pans.
  - GN 1/1 Full Size Food Pan capacity:
    - 24 each 2 1/2" (6,5 cm) deep
    - 16 each 4" (10 cm) deep
    - 12 each 6" (15 cm) deep
    - 8 each 8" (20 cm) deep
  - Sheet Pan capacity:
    - 12 / 22 each (requires 10 additional sets of slide rails)
- Inside cavity floor design allows water condensation or spills to be collected at the bottom without leaking out of the unit. Can be easily wiped down.
- Aluminum louvers located in the back wall of the cavity direct air flow for even distribution and are easy to remove and clean.
- Vent cap on each door allows steam to be released. Each door has a menu clip.
- Durable nylon door latch is easy to open and closes securely to provide maximum temperature retention. Magnetic seal gasket provides a tight seal for enhanced hot or cold temperature retention while still permitting easy opening and closing of the door.
- Doors swing open 270° to provide easy access to contents when removing or inserting food pans or sheet pans. Knuckle hinge mechanism makes them extra sturdy and easy to remove for cleaning.
- Ergonomic, molded-in steering handles provide comfortable, easy transporting.
- Choose from two caster configurations. All are non-marking rubber casters.
  - Models CMBH1826TSF, CMBH1826TSC
    - Four each 6" (15,2cm), 2 front swivel w/brake, 2 rear rigid.
  - Models CMBH1826TBF, CMBH1826TBC
    - Two each 6" (15,2cm) front swivel w/brake, 2 rear 10" (25,4cm) Big Wheels.
- Minimal assembly required.
- Available in 3 colors.



Works without hot coil or humidifier!

Warranty: One Year Parts and Labor

#### Approvals



© 2008 Cambro Manufacturing Company 5801 Skylab Road, Huntington Beach, California 92647-2056-U.S.A.  
Telephone (1)714 848 1555 Toll Free 800 854 7631 Customer Service 800 833 3003  
LIT FCST-0504

# Camtherm® Bulk Food Cabinets, Hot Only

## Tall Profile, Dutch Doors, Single Cavity

External Fahrenheit Thermometer

Model CMBH1826TSF, CMBH1826TBF

External Celsius Thermometer

Model CMBH1826TSC, CMBH1826TBC

Item No. \_\_\_\_\_

Specifier Identification No. \_\_\_\_\_

Model No. \_\_\_\_\_

Quantity \_\_\_\_\_

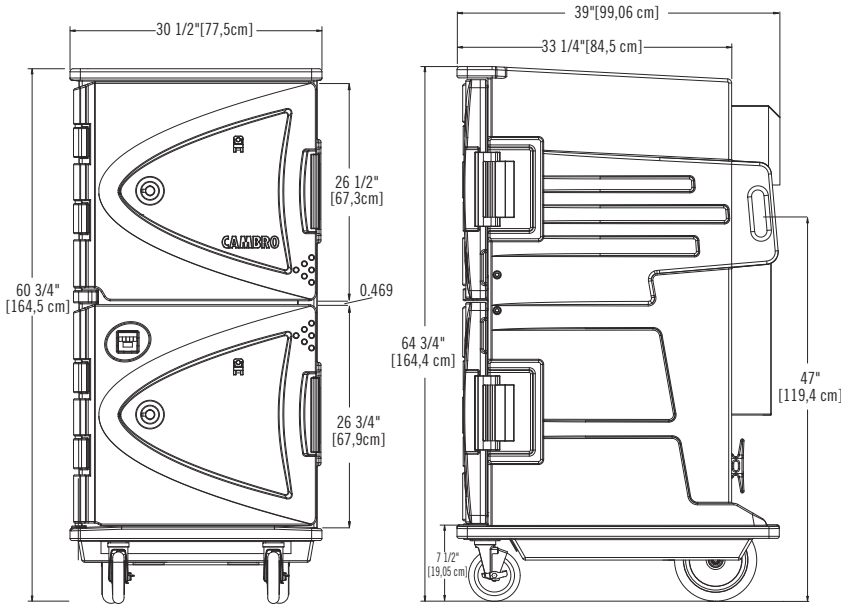

Front View

Side View  
(Big Wheel Only)

### HOT HOLDING

TIME	150°F (65°C)	165°F (74°C)
WARM UP TIME (empty) (from ambient to desired/set temperature)	30 minutes	60 minutes
RECOVERY TIME* (time to recover temperature after door is held open for 30 seconds)	1 minute	3 minutes
TRANSPORT TIME* (after reaching desired/set temperature, amount of time unit can be held passively/unplugged until temperature reaches 140°F (00°C).	4 hours	8 hours

\*Based on test with 6 each full size 6" (15,2cm) deep H-Pans™ filled with 190°F (87,7°C) hot water, covered and placed inside upper part of cabinet only.

### HOLDING CAPACITY (Includes 12 Rail Sets)

SIZE	QUANTITY
18" x 26" (45,7 x 66 cm) Sheet Pan	22*
12" x 20" (32,5 x 53 cm) Full Size Food Pan 2 1/2" (6,5 cm) Deep	24
12" x 20" (32,5 x 53 cm) Full Size Food Pan 4" (10 cm) Deep	16
12" x 20" (32,5 x 53 cm) Full Size Food Pan 6" (15 cm) Deep	12
12" x 20" (32,5 x 53 cm) Full Size Food Pan 8" (20 cm) Deep	8

\*Ten additional rail sets need to be purchased.

### ELECTRICAL

110V

Maximum amp draw	13.7
Amps run on	13.2
Watts	1800
Hertz	50/60
Power input (ground fault protected)	125 VAC

## Specifications

Dimension Tolerance: +/- 1/16" (0,64 cm)

Code	Caster	Thermometer	External Dimensions W x D x H	Unit Weight Lbs. (Kg)	Case Lbs. (cube)	Case kg (m³)
CMBH1826TSF	A	Fahrenheit	30 1/2" x 39" x 64 3/4" (77,5 x 99,1 x 164,5 cm)	263.64 (119,8)	292.64 (47.5)	133 (1,35)
CMBH1826TSC	A	Celsius	30 1/2" x 39" x 64 3/4" (77,5 x 99,1 x 164,5 cm)	263.64 (119,8)	292.64 (47.5)	133 (1,35)
CMBH1826TBF	B	Fahrenheit	30 1/2" x 39" x 64 3/4" (77,5 x 99,1 x 164,5 cm)	268 (122)	297 (47.5)	135 (1,35)
CMBH1826TBC	B	Celsius	30 1/2" x 39" x 64 3/4" (77,5 x 99,1 x 164,5 cm)	268 (122)	297 (47.5)	135 (1,35)

Colors: Granite Gray (191), Granite Green (192), Granite Sand (194).

### Caster Configuration:

A – 4 each 6" (15,2cm), 2 front swivel w/brake, 2 rear rigid

B – 2 each 6" (15,2cm) front swivel w/brake, 2 rear 10" (25,4cm) Big Wheels

Code	Description	Rail Dimensions W x D	Case Lbs. (cube)	Case kg (m³)
CMBR	Slide Rail Set	20" x 4 13/16" (50,8 x 12,2 cm)	2.25 (.11)	1,02 (0,003)

Camwear® Clear Polycarbonate and/or H-Pan™ High Heat Food Pans are recommended for use with the Camtherm Cart.

## Architect Specs

The Tall Camtherm Bulk Food Holding Cabinet, Hot Only, shall be Cambro Model .... manufactured by Cambro Manufacturing Company, Huntington Beach, CA 92647. Each cabinet shall be made of a polyethylene shell filled with foamed-in-place polyurethane and the single internal cabinet will be heated via an electric unit enclosed in a powder-coated steel encasement on the back of the unit. It shall have a 10' (305 cm) heavy gauge electrical cord with a wrapping hook on the back for convenient storage. It shall have double Dutch doors with nylon latches, magnetic gaskets; self-ventilating caps on each door and knuckle door hinges.

It shall have an internal Celsius or Fahrenheit thermometer with an external solar powered digital display panel on the lower door. It shall be available with either 4 each 6" (15,2 cm) front swivel w/brake and 2 rear rigid casters or with 2 each 6" (15,2 cm) front swivel w/brake and 2 rear 10" (25,4 cm) Big Wheels. All casters shall be non-marking. Colors offered shall be Granite Gray (191), Granite Green (192), and Granite Sand (194).

## Approvals



**CAMBRO**  
 MANUFACTURING COMPANY  
 www.cambro.com

© 2008 Cambro Manufacturing Company 5801 Skylab, Huntington Beach, California 92647-2056-U.S.A.

Telephone (1)714 848 1555 Toll Free 800 854 7631

Customer Service 800 833 3003 Printed in USA