



Item No. _____

Camtherm® Bulk Food Cabinets, Hot / Cold

Specifier Identification No. _____

Tall Profile, Dutch Doors, Single Cavity

Model No. _____

External Fahrenheit Thermometer

Model CMBHC1826TSF, CMBHC1826TBF

Quantity _____

External Centigrade Thermometer

Model CMBHC1826TSC, CMBHC1826TBC

Features & Benefits



- Unique and versatile plastic-based thermoelectric cart is designed for holding and transporting hot or cold food on or off-premise. Food remains at safe serving temperatures for hours.
- Thermoelectric unit located on back of unit is completely enclosed in a protective, powder coated, steel encasement. When the power is on, it will maintain the air temperature inside the cavity at an even range of 150°F (65°C) to 165°F (74°C) or 37°F (2,8°C) in accordance with HACCP guidelines. When heated to 165°F (74°C) and then turned off for passive holding or transporting, the temperature inside the cavity stays above 140°F (60°C) for 8 hours when the cabinet is full. When cooled to 37°F (2,7°C) and then turned off, the internal cavity temperature will remain below 41°F (5°C) for 1 hour when cabinet is full. Electrical cord length is 10' (305 cm) and there is a wrapping hook for easy storage.
- Easy-to-use control panel includes a virtually unbreakable, polycarbonate waterproof cover, on-off power switch, temperature setting dial, auto green light for "power on" indicator and auto red light for "temperature achieved."
- Internal thermometer on lower door with a solar powered external digital display available in either Fahrenheit or Centigrade so cavity temperatures can be checked at a glance.
- Double wall, polyethylene external construction is impact resistant and will not dent, crack, bubble, chip or break. Thick, polyurethane foam insulation helps to ensure excellent food temperature retention during holding and transporting.
- Includes anodized aluminum uprights and 12 sets of easy to remove chrome plated steel slide rails for full size food pans and/or 18" x 26" (45,7 x 66 cm) sheet pans.
 - GN 1/1 Full Size Food Pan capacity:
 - 24 each 2 1/2" (6,5 cm) deep
 - 16 each 4" (10 cm) deep
 - 12 each 6" (15 cm) deep
 - 8 each 8" (20 cm) deep
 - Sheet Pan capacity:
 - 12 / 22 each (requires 10 additional sets of slide rails)
- Inside cavity floor design allows water condensation or spills to be collected at the bottom without leaking out of the unit. Can be easily wiped down.
- Aluminum louvers located in the back wall of the cavity direct air flow for even distribution and are easy to remove and clean.
- Vent cap on each door allows steam to be released. Each door has a menu clip.
- Durable nylon door latch is easy to open and closes securely to provide maximum temperature retention. Magnetic seal gasket provides a tight seal for enhanced hot or cold temperature retention while still permitting easy opening and closing of the door.
- Doors swing open 270° to provide easy access to contents when removing or inserting food pans or sheet pans. Knuckle hinge mechanism makes them extra sturdy and easy to remove for cleaning.
- Ergonomic, molded-in steering handles provide comfortable, easy transporting.
- Choose from two caster configurations. All are non-marking rubber casters.
 - Models CMBHC1826TSF, CMBHC1826TSC
 - Four each 6" (15,2cm), 2 front swivel w/brake, 2 rear rigid.
 - Models CMBHC1826TBF, CMBHC1826TBC
 - Two each 6" (15,2cm) front swivel w/brake, 2 rear 10" (25,4cm) Big Wheels.
- Minimal assembly required.
- Available in 3 colors.



Works without compressor, hot coil or humidifier!

Warranty: One Year Parts and Labor

Approvals



© 2004 Cambro Manufacturing Company 5801 Skylab Road, Huntington Beach, California 92647-2056-U.S.A.
Telephone (1)714 848 1555 Toll Free 800 854 7631 Customer Service Hot Line 800 833 3003
LIT FCST-0504

Camtherm® Bulk Food Cabinets, Hot / Cold

Tall Profile, Dutch Doors, Single Cavity

External Fahrenheit Thermometer

Model CMBHC1826TSF, CMBHC1826TBF

External Centigrade Thermometer

Model CMBHC1826TSC, CMBHC1826TBC

Item No. _____

Specifier Identification No. _____

Model No. _____

Quantity _____

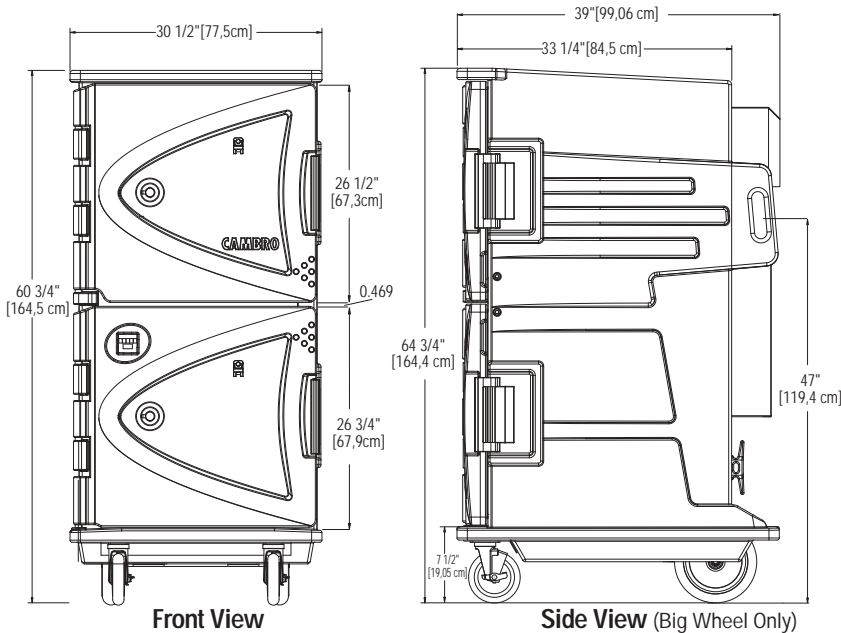

HOT HOLDING

TIME	150°F (65°C)	165°F (74°C)
WARM UP TIME (empty) (from ambient to temperature)	45 minutes	75 minutes
RECOVERY TIME* (time to recover to temperature after door is held open for 30 seconds)	1 minute	3 minutes
TRANSPORT TIME* (after reaching temperature, amount of time unit can be held passively/unplugged until temperature reaches 140°F (60°C).	6 hours	8 hours

* Based on test with 6 each full size 6" (15,2cm) deep H-Pans™ filled with 190°F (87,7°C) hot water, covered and placed inside upper part of cabinet only.

COLD HOLDING

TIME	37°F (2,7°C)
COOLING TIME (empty) (from ambient to temperature)	75 minutes
RECOVERY TIME* (time to recover to temperature after door is held open for 30 seconds)	4 minutes
TRANSPORT TIME* (after reaching temperature, amount of time unit can be held passively/unplugged until temperature reaches 41°F (5°C).	1 hour

* Based on test with 6 each full size 6" (15,2cm) deep Camwear® Pans filled with 34°F ((1,1°C) cold water, covered and placed inside upper part of cabinet only.

HOLDING CAPACITY (Includes 12 Rail Sets)

SIZE	QUANTITY
18" x 26" (45,7 x 66 cm) Sheet Pan	12 / 22*
12" x 20" (32,5 x 53 cm) Full Size Food Pan 2 1/2" (6,5 cm) Deep	24
12" x 20" (32,5 x 53 cm) Full Size Food Pan 4" (10 cm) Deep	16
12" x 20" (32,5 x 53 cm) Full Size Food Pan 6" (15 cm) Deep	12
12" x 20" (32,5 x 53 cm) Full Size Food Pan 8" (20 cm) Deep	8

*Requires Ten additional rail sets.

ELECTRICAL

110V

Maximum amp draw	13.7
Amps run on	13.2
Watts	1800
Hertz	50/60
Power input (ground fault protected)	125 VAC

Specifications

Dimension Tolerance: +/- 1/4" (0,64 cm)

Code	Caster	Thermometer	External Dimensions W x D x H	Unit Weight Lbs. (Kg)	Case Lbs. (cube)	Case kg (m³)
CMBHC1826TSF	A	Fahrenheit	30 1/2" x 39" x 64 3/4" (77,5 x 99,1 x 164,5 cm)	325.5 (148)	354.5 (47.5)	161,1 (1,35)
CMBHC1826TSC	A	Celsius	30 1/2" x 39" x 64 3/4" (77,5 x 99,1 x 164,5 cm)	325.5 (148)	354.5 (47.5)	161,1 (1,35)
CMBHC1826TBF	B	Fahrenheit	30 1/2" x 39" x 64 3/4" (77,5 x 99,1 x 164,5 cm)	329.82 (149.9)	358.82 (47.5)	163,1 (1,35)
CMBHC1826TBC	B	Celsius	30 1/2" x 39" x 64 3/4" (77,5 x 99,1 x 164,5 cm)	329.82 (149.9)	358.82 (47.5)	163,1 (1,35)

Colors: Granite Gray (191), Granite Green (192), Granite Sand (194).

Caster Configuration:

A – 4 each 6" (15,2cm), 2 front swivel w/brake, 2 rear rigid
 B – 2 each 6" (15,2cm) front swivel w/brake, 2 rear 10" (25,4cm) Big Wheels

Code	Description	External Dimensions W x D	Case Lbs. (cube)	Case kg (m³)
------	-------------	---------------------------	------------------	--------------

Accessories

CMBR	Slide Rail Set	20" x 4 13/16" (50,8 x 12,2 cm)	2.25 (.11)	1,02 (0,003)
------	----------------	---------------------------------	------------	--------------

Camwear® Clear Polycarbonate and/or H-Pan™ High Heat Food Pans are recommended for use with the Camtherm Cart.

Architect Specs

The Tall Camtherm Bulk Food Holding Cabinet, Hot/Cold, shall be Cambro Model... manufactured by Cambro Manufacturing Company, Huntington Beach, CA 92647. Each cabinet shall be made of a polyethylene shell filled with foamed-in-place polyurethane and the single internal cabinet will be heated or chilled via a thermoelectric unit enclosed in a powder-coated steel encasement on the back of the unit. It shall have a 10' (305 cm) heavy gauge electrical cord with a wrapping hook on the back for convenient storage. It shall have double Dutch doors with nylon latches, magnetic gaskets; self-ventilating caps on each door and knuckle door hinges.

It shall have an internal Centigrade or Fahrenheit thermometer with an external solar powered digital display panel on the lower door. It shall be available with either 4 each 6" (15,2 cm) front swivel w/brake and 2 rear rigid casters or with 2 each 6" (15,2 cm) front swivel w/brake and 2 rear 10" (25,4 cm) Big Wheels. All casters shall be non-marking. Colors offered shall be Granite Gray (191), Granite Green (192), and Granite Sand (194).

Approvals



CAMBRO
 MANUFACTURING COMPANY
 www.cambro.com

© 2004 Cambro Manufacturing Company 5801 Skylab, Huntington Beach, California 92647-2056-U.S.A.
 Telephone (1)714 848 1555 Toll Free 800 854 7631 Customer Service Hot Line 800 833 3003

Printed in USA